

# STEERING SYSTEM

## Return To Main Table of Contents

GENERAL .....	2
STEERING COLUMN AND SHAFT .....	14
MANUAL STEERING GEAR BOX .....	20
TIE ROD .....	28
POWER STEERING GEAR BOX .....	31
POWER STEERING OIL PUMP .....	43
POWER STEERING HOSES .....	48

## GENERAL SPECIFICATIONS

### Manual Steering

Shaft and joint type	Collapsible, cross joints (two joints used)
Steering gear type	Rack and pinion
Rack stroke	132 mm (lock to lock : 3.7 turns)

### Power Steering

Shaft and joint type	Collapsible, cross joints, tilt column with pop-up
Steering gear type	Rack and pinion
Rack stroke	132 mm (lock to lock : 2.89 turns)
Oil pump type	Vane type
Oil pump displacement	9.6 cm <sup>3</sup> /rev. (0.59 in <sup>3</sup> /rev.)
Oil pump pressure switch operating pressure	1.5-2.0 MPa (15-20 kg/cm <sup>2</sup> , 213-284 psi)

## SERVICE STANDARD

### Manual Steering

Standard value	0-30 mm (0-1.1 in.)
Steering wheel free play	
Steering angle	
Inner wheel	37°40' ± 1°5'
Outer wheel	31°52'
Difference between LH and RH	2" or less
Tie rod end ball joint starting torque	0.5-2.5 Nm (5-25 kg.cm, 4-22 lb.in.)
Total pinion preload	
±180° or less from neutral	0.4-1.1 Nm (4-11 kg.cm, 3.5-9.5 lb.in.)
±180° or more from neutral	0.3-1.6 Nm (3-16 kg.cm, 2.6-14 lb.in.)
Tie rod swing resistance	2-5 Nm (20-50 kg.cm, 1.4-3.6 lb.ft)

### Power Steering

Standard value	
Steering wheel free play	0-30 mm (0-1.1 in.)
Steering angle	
Inner wheel	37°40' ± 1°5'
Outer wheel	31°52'
Difference between LH and RH	2° or less
Stationary steering effort	39.23 N (4 kg, 8.8 lbs) or less
Belt deflection [under 98N (10 kg, 22 lb) force]	7-10 mm
Oil pump relief pressure	6.2 MPa (65 kg/cm <sup>2</sup> , 924 psi)
Total pinion preload (MANDO)	0.6-1.3 Nm (6-13 kg.cm, 5.2-11.3 lb.in.)
Total pinion preload (TRW)	0.6-1.5 Nm (6-15 kg.cm, 5.2-13.2 lb.in.)
Tie rod swing resistance	2-5 Nm (20-50 kg.cm, 1.4-3.6 lb.ft)



**TIGHTENING TORQUE**



	Nm	kg.cm	lb.ft
Steering wheel lock nut	35-45	350-450	26-33
Steering column and shaft assembly mounting bracket	13-18	130-180	10-13
Steering shaft and joint	15-20	150-200	11-15
Pinion gear and joint	15-20	150-200	11-15
Dust cover mounting bolt	4-6	40-60	3-4.4
Gear box mounting clamp	60-80	600-800	44-59
Tie rod end lock nut	50-55	500-550	37-41
Tie rod end ball joint slotted nut	15-34	150-340	11-25
Rack support cover lock nut	50-70	500-700	37-52
Rack support cover	7-12	70-120	5-9
Tie rod to rack	80-100	800-1000	59-74
<b>[power steering only]</b>			
Valve body housing to rack housing assembly	20-30	200-300	15-22
Pressure and return tube mounting clip	8-12	80-120	6-9
Pressure and return tube to gear box (MANDO)	12-18	120-180	9-13
Pressure and return tube to gear box (TRW)	20-27	200-270	15-20
Pinion valve lock nut (MANDO)	20-30	200-300	15-22
Pinion valve lock nut (TRW)	24-34	240-340	18-25
Rack support plug lock nut (MANDO)	50-70	500-700	37-52
Tie rod to rack (TRW)	68-88	680-880	50-65
End plug (MANDO)	50-70	500-700	36-51
End plug (TRW)	21-35	210-350	15-26
Oil pump mounting bracket bolt	20-27	200-270	15-20
Oil pump adjusting bolt	25-33	250-330	18-24
Pressure hose mounting nut (to oil pump)	16-24	160-240	12-18
Oil reservoir mounting bolt	8-12	80-120	6-9
Return hose mounting clamp (to oil pump suction connector)	3-5	30-50	2.2-3.6
Oil cooler tube mounting clip	8-12	80-120	6-9

**LUBRICANTS**

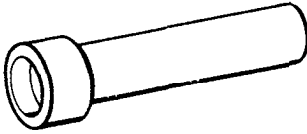
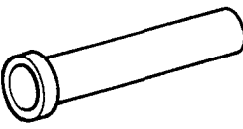
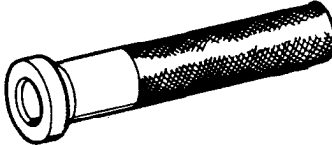
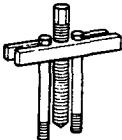
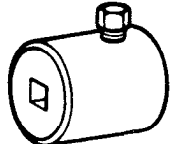
	Recommended lubricant	Quantity
Teeth of rack and pinion	Multipurpose grease SAE J310, NLGI No.2	As required
Moving parts of rack and bushings	Multipurpose grease SAE J310, NLGI No.2	As required
Moving parts of pinion and needle bearing	Multipurpose grease SAE J310, NLGI No.2	As required
Lip of gear box oil seal	Multipurpose grease SAE J310, NLGI No.2	As required
Tie rod side groove of bellows	Multipurpose grease SAE J310, NLGI No.3	As required
Inside surface and lip of tie rod end dust cover	Multipurpose grease SAE J310, NLGI No.2	As required
Power steering fluid	ATF DEXRONell type	0.9 liter (0.95 qts.)

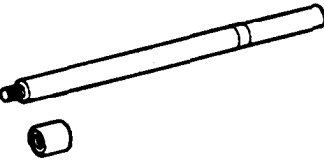
## SPECIAL TOOLS

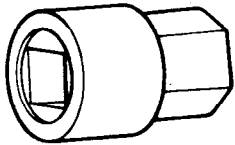
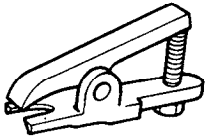
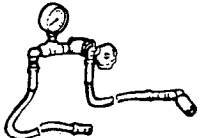
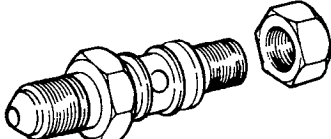
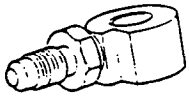
Tool (Number and name)	Illustration	Use
09517-21400 Drift		Removal of pinion gear bearing.
09222-21100 Valve stem oil seal installer		Installation of the pinion gear bearing.
09432-21600 Bearing installer		Installation of the pinion gear bearing.
09434-14200 Counter shaft bearing installer		Installation of the valve housing oil seal.
09561-11002 (J-1859-03) Steering wheel puller		Removal of the steering wheel.
09565-11100 Pre-load socket		Measurement of the mainshaft pre load.
09565-21000 Pinion bearing remover and installer		Removal & installation of pinion gear bearing.
09555-21000 Bar		Removal & installation of the oil seal.

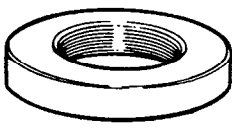
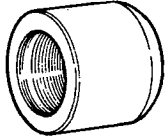
Tool (Number and name)	Illustration	Use
09565-21100 Yoke plug torque wrench socket		Removal, installation and adjustment of steering gear yoke plug.
09568-31000 Tie rod end puller		Separation of the tie rod end ball joint.
09572-21000 Oil pressure gauge		Measurement of the oil pressure. (use with 09572-33100, 09572-21200, 09572-32100)
09572-21200 Oil pressure gauge adapter		Measurement of the oil pressure. (use with 09572-21000, 09572-33100)
09572-33100 Oil pressure gauge adapter		Measurement of the oil pressure. (use with 09572-21000, 09572-21200)
09573-21000 Oil seal installer gauge		Installation of the back-up washer and oil seal. (use with 09573-21100, 09573-21200, 09517-11000, 09555-21000)
09573-21100 Oil seal installer		Installation of the back-up washer and oil seal. (use with 09573-21000, 09573-21200, 09555-21000)
09573-21200 Oil seal guide		Removal & installation of the oil seal. (use with 09573-21000, 09573-21100, 09555-21000)

**TROUBLESHOOTING (Manual Steering)**

Symptom	Probable cause	Remedy
Excessive play of steering wheel	Loose rack support cover Loose steering gear mounting bolts Loose or worn tie-rod end	Retighten Retighten Retighten or replace as necessary
Steering wheel operation is hard	Excessive turning resistance of tie-rod ball joint Excessively tightened rack support cover Rough turning of inner tie-rod and/or ball joint Distorted rack Worn steering shaft joint and/or body grommet Damaged pinion bearing	Replace Adjust Lubricate or replace ball joint Replace Replace Replace
Steering wheel does not return properly	Excessive turning resistance of tie-rod ball joint Excessively tightened rack support cover Rough turning of inner tie-rod and/or ball joint Worn steering shaft joint and/or body grommet Distorted rack Damaged pinion bearing	Replace Adjust Replace Correct or replace Replace Replace

**TROUBLESHOOTING (Power Steering)**

Symptom	Probable cause	Remedy
Excessive play of steering wheel	Loose rack support cover Loose steering gear mounting bolts Loose or worn tie-rod end	Retighten Retighten Retighten or replace as necessary
Steering wheel operation is heavy (Insufficient power assist)	V-belt slippage Damaged V-belt Low fluid level Air in the fluid Twisted or damaged hoses Insufficient oil pump pressure Sticky flow control valve Excessive internal oil pump leakage Excessive oil leaks from rack and pinion in gear box Distorted or damaged gear box or valve body seal ring	Check Replace Replenish Bleed air Correct the routing or replace Repair or replace the oil pump Replace Replace damaged parts Replace damaged parts  Replace
The steering wheel does not return properly	Excessive turning resistance of tie-rod end Excessively tightened rack support cover Rough turning or inner tie-rod and/or ball joint Loose mounting of gear box to gear box mounting bracket Worn steering shaft joint and/or body grommet Distorted rack Damaged pinion bearing Twisted or damaged hoses Damaged oil pressure control valve Damaged oil pump input shaft bearing	Replace Adjust Replace Retighten  Correct or replace Replace Replace Reroute or replace Replace Replace
Noise	<b>Hissing Noise in Steering Gear</b> There is some noise in all power steering systems. One of the most common is a hissing sound when the steering wheel is turned and the car is not moving. This noise will be most evident when turning the wheel while the brakes are applied. There is no relationship between this noise and steering performance. Do not replace the valve unless the "hissing" noise is extremely objectionable. A replacement valve will also have a slight noise, and is not always a cure for the condition.	

Symptom	Probable cause	Remedy
Rattling or chucking noise in rack and pinion	Interference with hoses from vehicle body Loose gear box bracket Loose tie-rod end and/or ball joint Worn tie-rod end and/or ball joint	Re-route Retighten Retighten Replace
Noise in the oil pump	Low fluid level Air in the fluid Loose pump mounting bolts	Replenish Bleed air Retighten

A slight "grinding noise" may be heard immediately after the engine is started in extremely cold weather condition (below -20°C): This is due to power steering fluid characteristics in extreme cold conditions and is not a malfunction.

**SERVICE ADJUSTMENT PROCEDURE**

**Checking Steering Wheel Free Play**

1. Start the engine and with the steering wheel in the straight ahead position, apply a force of 5 N (1.1 lb) while turning the steering wheel.
2. Measure the play at the circumference of the steering wheel.

Steering wheel free play [Standard value] .....  
 O-30 mm (0-1.1 in.)

3. If the play exceeds the standard value, inspect the contact of the steering shaft and tie rod ends.

**Checking Steering Angle**

1. Place the front wheel on a turning radius gauge and measure the steering angle.

Steering angle [Standard value]  
 Inner wheel .....  $37^{\circ}40' \pm 1^{\circ}5'$   
 Outer wheel .....  $31^{\circ}52'$

2. If the measured value is not within the standard value, adjust the linkage.

**Checking Tie Rod End Ball Joint Starting Torque**

1. Mount two nuts on the ball joint, and then measure the starting torque.

Tie rod end ball joint starting torque  
 [Standard value] .....  
 0.5-2.5 Nm (5-25 kg.cm, 4.3-21.7 lb.in.)

2. If the starting torque exceeds the standard value, replace the tie rod end.

**NOTE**

Even if the starting torque is below limit of the standard value, the ball joint may be reused unless it has drag and excessive play.

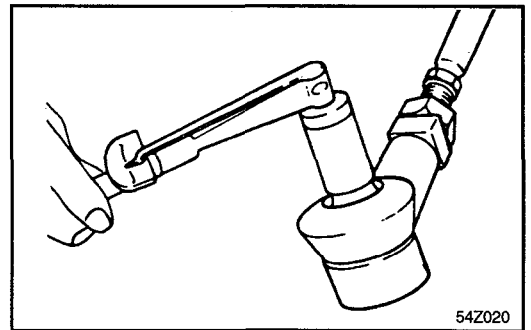
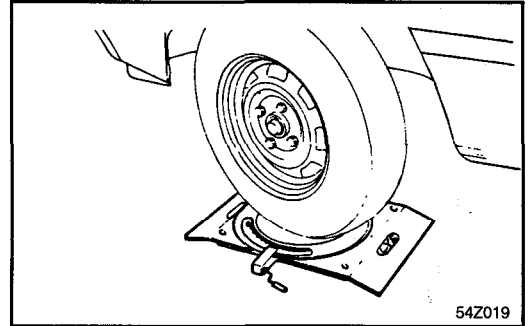
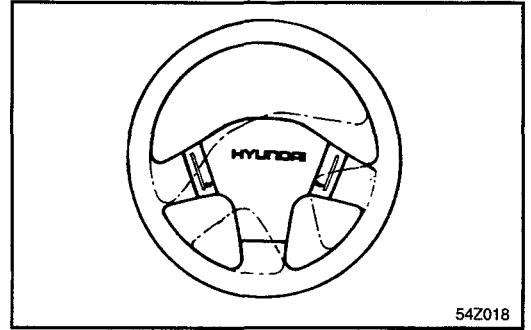

### Checking Stationary Steering Effort (power steering)

1. Place the vehicle on a level surface and place the steering wheel in the straight ahead position.
2. Increase the engine speed to 1,000 rpm.

#### CAUTION

**After checking, reset the engine speed to the standard value (idling speed).**

3. Measure the turning force with a spring scale by turning the steering wheel clockwise and counterclockwise one and a half turns.

---

Stationary steering effort [Standard value] .....  
39.23 N (4 kg, 8.8 lbs) or less

---

4. Check that there is no excessive force change while turning the steering wheel.
5. If the stationary steering effort is excessive, check and adjust the following points:
  - 1) Damage or cracks of the dust covers of the lower arm ball joint and tie rod end.
  - 2) Pinion preload of the steering gear box and turning starting torque of the tie rod end ball joint.
  - 3) Turning starting torque of the lower arm ball joint.

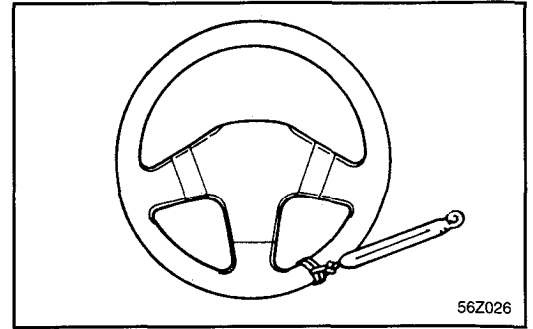

### Checking Steering Wheel Return

Check the steering wheel return and confirm the following points:

1. The force required to turn the steering wheel and the wheel return should be the same for both moderate and sharp turns.
2. When the steering wheel is turned 90° and held for a couple of seconds while the vehicle is being driven at 35 km/h (22 mph), the steering wheel should return at least 70% when it is released.

#### NOTE

**If the steering wheel is turned very quickly, operation may be momentarily heavy. This is not a malfunction, especially during idling, because the oil pump output will be somewhat decreased.**

## Checking Power Steering Fluid Level

1. Position the vehicle on a level surface.
2. Start the engine. With the vehicle kept stationary, turn the steering wheel several times continuously to raise the fluid temperature from 50-60°C (122-140°F).
3. With the engine at idle, turn the steering wheel fully clockwise and counterclockwise several times.
4. Make sure there is no foaming or cloudiness in the reservoir fluid.
5. Stop the engine to check for a difference in fluid level between a stationary and a running engine.

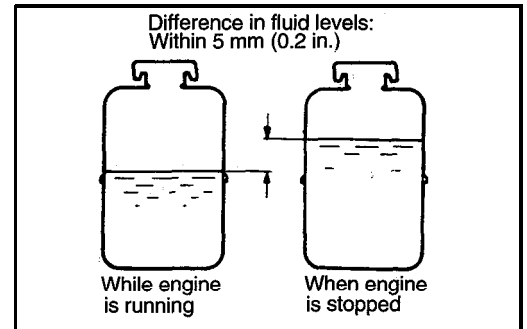

### NOTE

- 1) If the fluid level varies 5 mm (0.2 in.) or more, bleed the system again.
- 2) If the fluid level suddenly rises after stopping the engine, insufficient bleeding is indicated.
- 3) Incomplete bleeding will produce a chattering sound in the pump and a noise in the flow control valve, decreasing durability of the pump.

## Replacing Power Steering Fluid

1. Jack up the front of the car and support with rigid racks.
2. Disconnect the return hose from the oil reservoir and plug the oil reservoir.
3. Connect a hose to the disconnected return hose, and drain the oil into a container.
4. Disconnect the high-tension cable at the ignition coil side. While operating the starter motor intermittently, turn the steering wheel all the way to the left and then to the right several times to drain the fluid.
5. Connect the return hoses, then fill the oil reservoir with the specified fluid.
6. Bleed the system.  
Automatic transmission fluid DEXRONE II type:  
Total quantity : Approx. 0.9 liter (0.95 qts.)

## Air Bleeding

1. Jack up the front wheels and support them by using a floor stand.
2. Manually turn the oil pump pulley a few times.
3. Turn the steering wheel all the way to the left and to the right five or six times.
4. Disconnect the high tension cable, and then, while operating the starter motor intermittently (for 15 to 20 seconds), turn the steering wheel all the way to the left and then to the right five or six times.

### CAUTION

- 1) During air bleeding, replenish the fluid supply so that the level does not fall below the lower position of the filter.
- 2) If air bleeding is done while the vehicle is idling, the air will be broken up and absorbed into the fluid. Be sure to do the bleeding only while cranking.

5. Connect the high tension cable, and then start the engine.
6. Turn the steering wheel to the left and then to the right, until there are no air bubbles in the oil reservoir.

**CAUTION**

**Do not hold the steering wheel turned all the way to either stop for longer than ten seconds.**

7. Confirm that the fluid is not milky, and that the level is up to the specified position.
8. Check that there is little change in the fluid level when the steering wheel is turned left and right.

**CAUTION**

- 1) If the level of the fluid changes considerably, air bleeding should be done again.
- 2) If the fluid level rises suddenly when the engine is stopped, it indicates that there is still air in the system.
- 3) If there is air in the system, a jingling noise may be heard from the pump and the control valve. Air in the system will shorten the life of the pump and other parts.

**Checking Power Steering Belt Tension**

1. Depress the V-belt by applying a pressure of 98 N (10 kg, 22 lb) at the specified point, and measure the deflection to confirm that it is within the standard value.

V-belt deflection [Standard value] . . . . . \*  
 7-10 mm (0.28-0.39 in.)

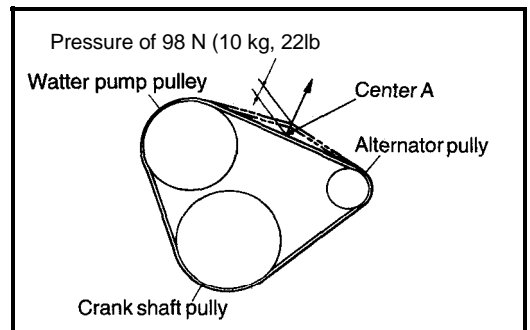

2. To adjust the belt tension, loosen the oil pump mounting bolts, move the oil pump, and then retighten the bolts.

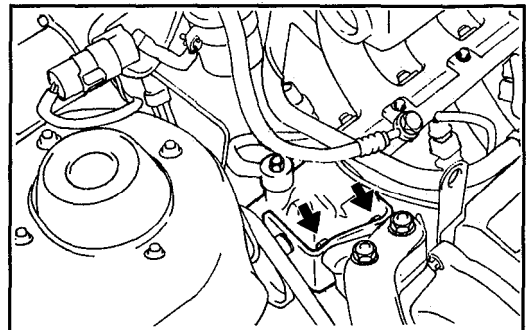

**Oil Pump Pressure Test**

1. Disconnect the pressure hose from the oil pump. Connect the special tool between the oil pump and pressure hose as illustrated.
2. Bleed the air, and then start the engine and turn the steering wheel several times so that the fluid temperature rises to approximately 50°C (122°F).
3. Increase the engine speed to 1,000 rpm.
4. Close the shut-off valve of the special tool and measure the fluid pressure to confirm that it is within the standard value range.

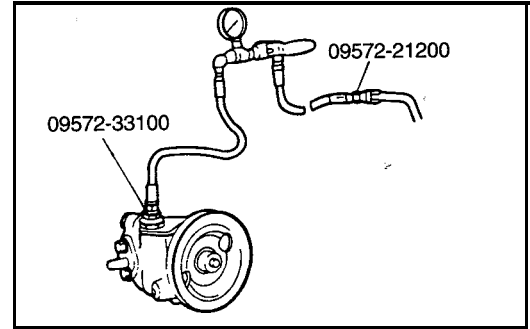

---

Oil pump pressure [Standard value]  
 Relief pressure ..... 6.2 MPa (65 kg/cm<sup>2</sup>, 924 psi)

---

**CAUTION**  
**Do not keep the shut-off valve on the pressure gauge closed for no more than ten seconds.**

5. Remove the special tools, and tighten the pressure hose to the specified torque.

---

Tightening torque .....  
 16-24 Nm (160-240 kg.cm, 12-18 lb.ft)

---

6. Bleed the system.

STEERING COLUMN AND SHAFT

COMPONENTS

[NORMAL]

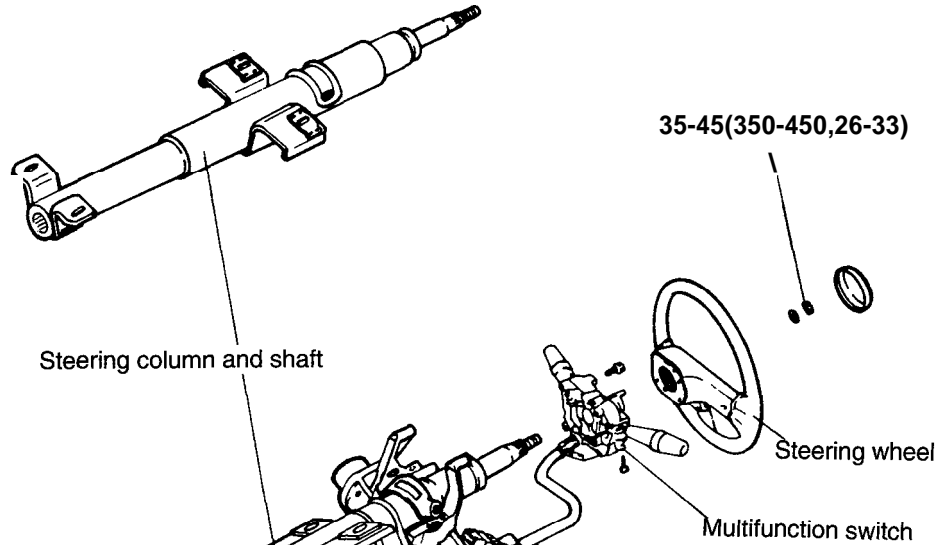

[TILT STEERING]

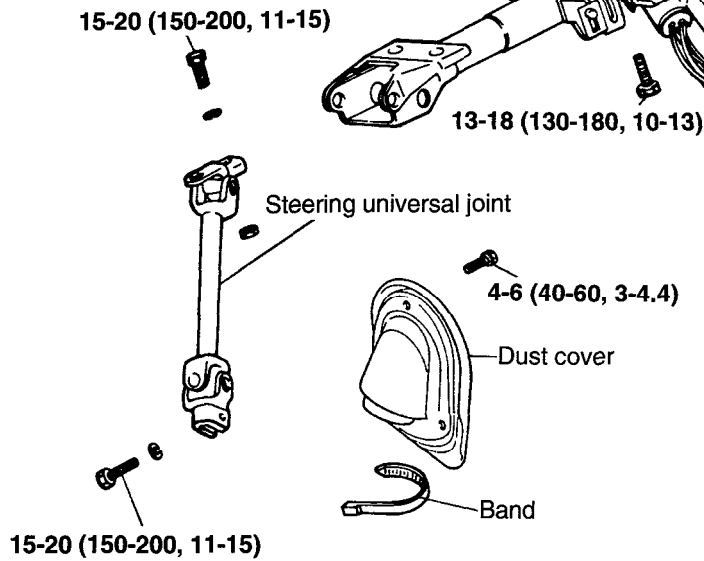

TORQUE : Nm (kg.cm, lb.ft)

**REMOVAL**

1. Remove the horn cover assembly.
2. Remove the upper and lower horn plate, and disconnect the horn button connector.

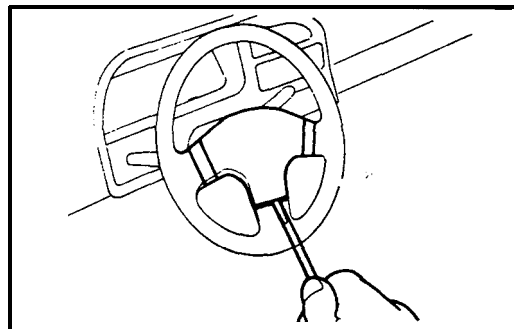

3. Remove the steering wheel lock nut.
4. After making alignment marks on the steering shaft and wheel, remove the steering wheel, using the Special Tool (09561-11002).

**CAUTION**

**Do not hammer on the steering wheel to remove it: doing so may damage the steering column.**

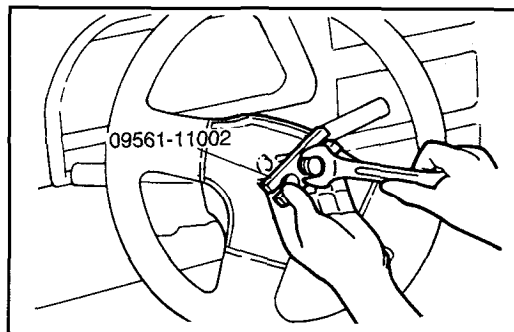

5. Remove the lower crash pad, and disconnect the rheostat connector.
6. Remove the column shroud.

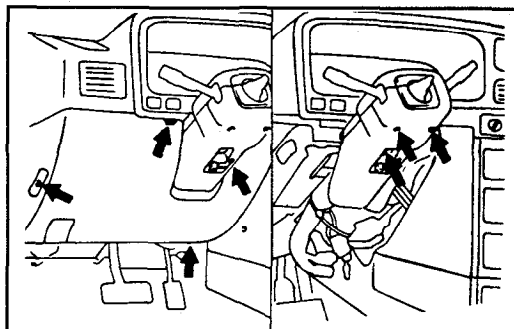

7. Disconnect the connectors.

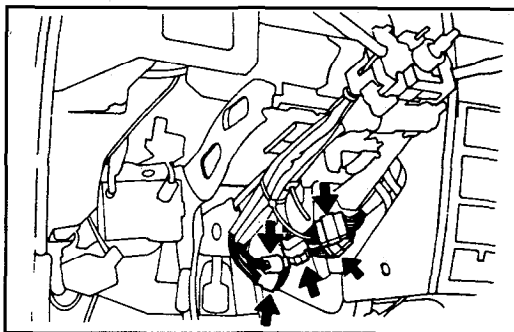

8. Remove the multifunction switch.

9. Remove the bolt coupling the universal joint and pinion.

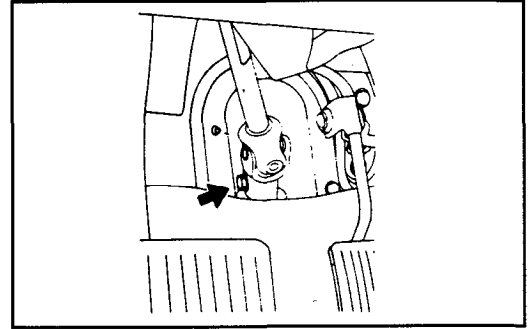

10. After removing the bolts used to secure the column bracket to the frame, remove the steering column and shaft assembly.

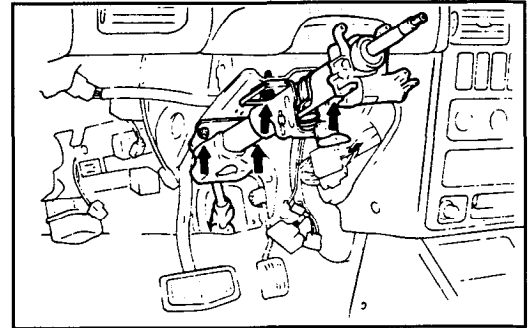

## DISASSEMBLY

1. Loosen the column shaft to universal joint bolt, and remove the universal joint.

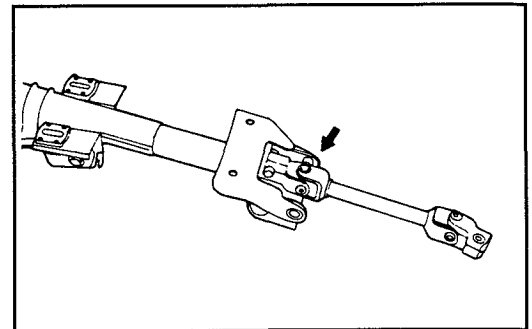

2. If necessary to remove the steering lock, cut a slot in the mounting screw heads and bracket with a hack saw. Loosen the screws with a flat-blade screwdriver to remove the steering wheel lock.

### CAUTION

When the steering wheel lock is reinstalled, the steering wheel lock assembly and screws should be replaced with new parts.

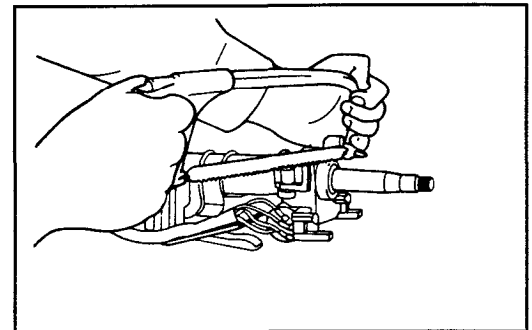

3. If necessary, remove the tilt steering lever and mounting bracket. (Tilt steering only)

### NOTE

Do not disassemble the steering column and shaft.

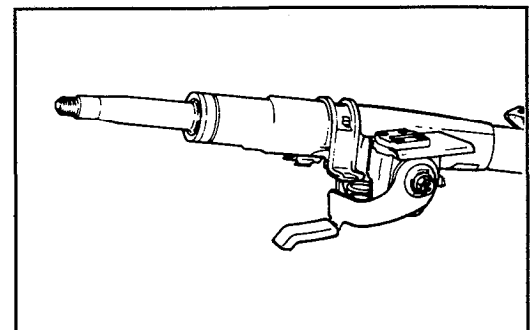

## INSPECTION

1. Check the steering column and shaft for damage and distortion.
2. Check the joints for play, damage or rough movement.
3. Check the tilt bracket and spring for cracks and damage.
4. Check that the steering lock mechanism operates properly.
5. Check the dust cover for cracks or damage.  
If necessary, replace.

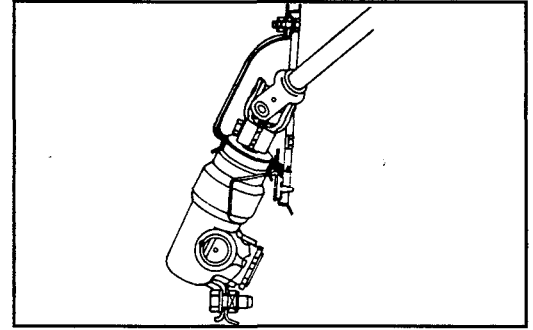

## ASSEMBLY

1. Assembly is reverse of the disassembly procedure.
2. Align the steering lock with the column boss and insert the ignition key to verify the steering lock operation before tightening the lock to specifications.

### CAUTION

Use the special one way screws to install the lock.

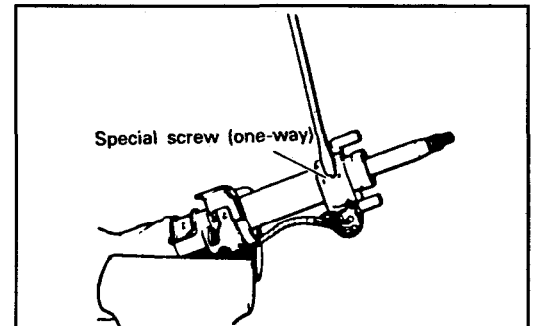

## INSTALLATION

### [NORMAL]

1. Installation the universal joint to the column shaft.

### NOTE

Make sure that the joint is installed in the correct direction as illustrated. In securing, be sure that bolt is installed correctly to the gear box pinion groove and the end of bolt is protruded on the opposite side of the universal joint yoke.

2. Mount the steering column shaft to the mounting frame.

### CAUTION

When installing, be careful not to distort the steering column.

3. Install the multifunction switch and connect the connectors.
4. Install the column shroud.
5. Connect the rheostat connector and install the lower crash pad.
6. Install the steering wheel.

### NOTE

When the steering wheel is installed, make sure that the alignment marks are in alignment and that the steering wheel is in the straight ahead position.

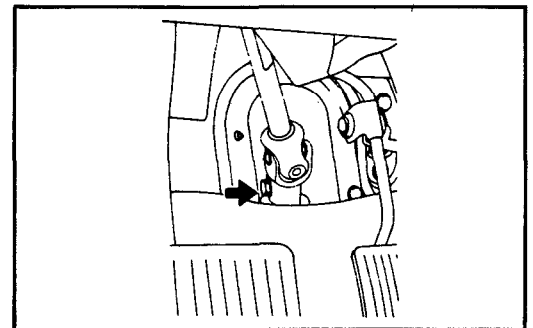
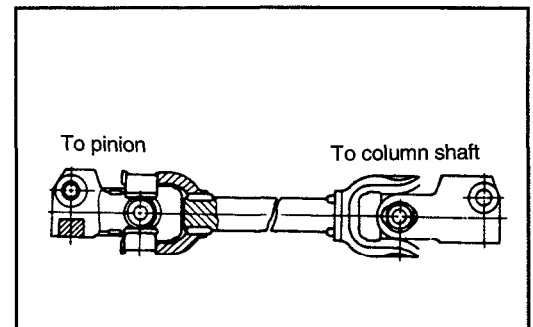

[TILT STEERING]

1. Installation the universal joint to the gear box.

**NOTE**

**In case of the tilt steering column, please observe the following.**

**Failure to observe these instructions could be a cause of the deformation of the tilt bracket which may result in heavy tilt lever operation and inoperative pop-up.**

2. Before installation, make sure if a pin hole exists on the distance bracket.
  - 1) If it does, lock the tilt around a neutral position and install a pin stopper (P/No. : 56357-24100) to the hole. And then unlock the tilt lever.
  - 2) If not, lock the tilt around a neutral position.

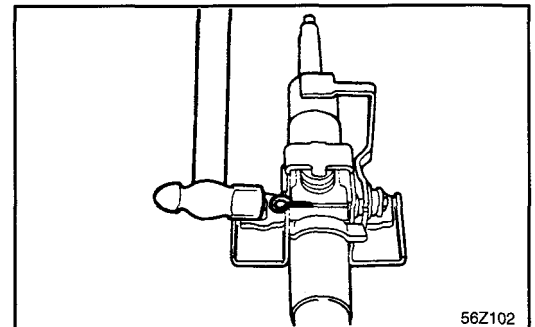
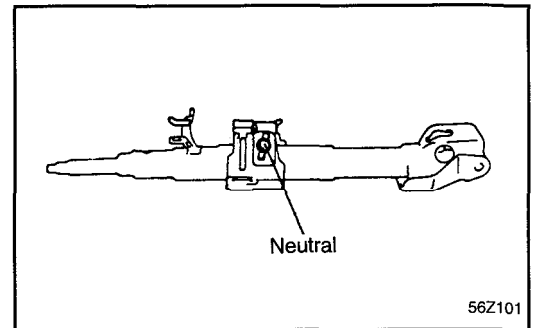

3. Install the bolt coupling the column shaft with the U-joint.

Specified torque .....	15-20 Nm (150-200 kg.cm, 11-15 lb.ft)
------------------------	---------------------------------------

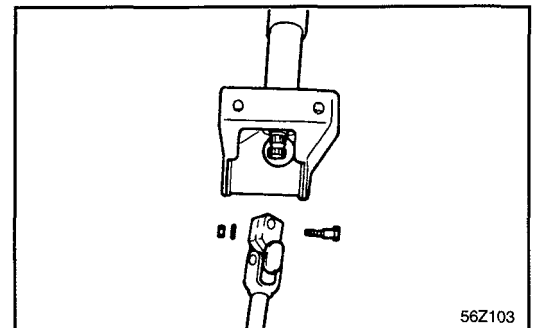

4. Install two mounting bolts temporarily.

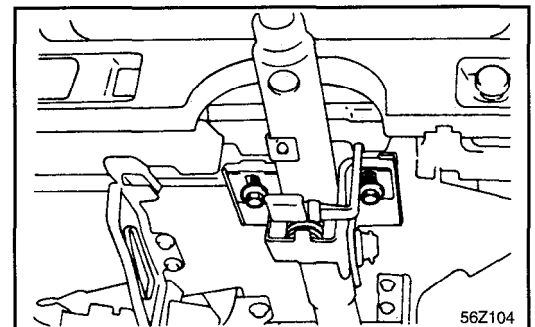

5. Install two mounting nuts.

---

Specified torque .....  
13-18 Nm (130-180 kg.cm, 10-13 lb.ft)

---

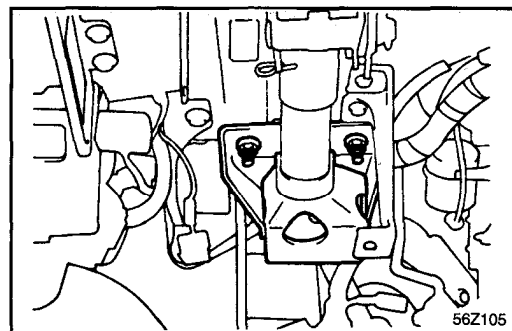

6. Tighten the two mounting bolts completely.

---

Specified torque .....  
13-18 Nm (130-180 kg.c., 10-13 lb.ft)

---

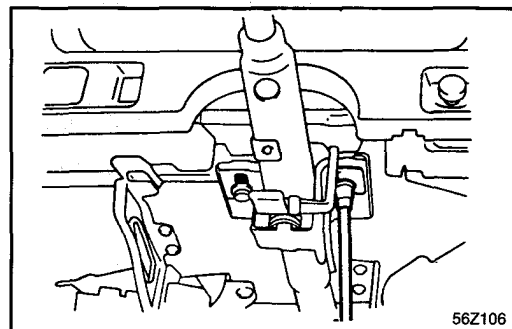

7. If the pin stopper is installed, pull it off in a low tilt position.

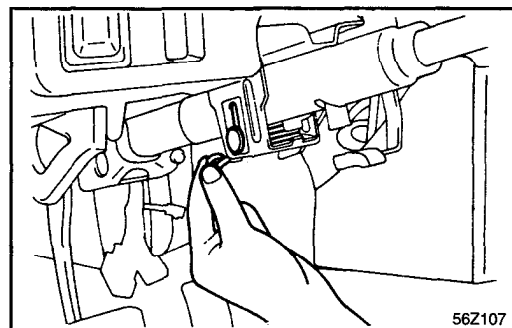

## MANUAL STEERING GEAR BOX

## COMPONENTS

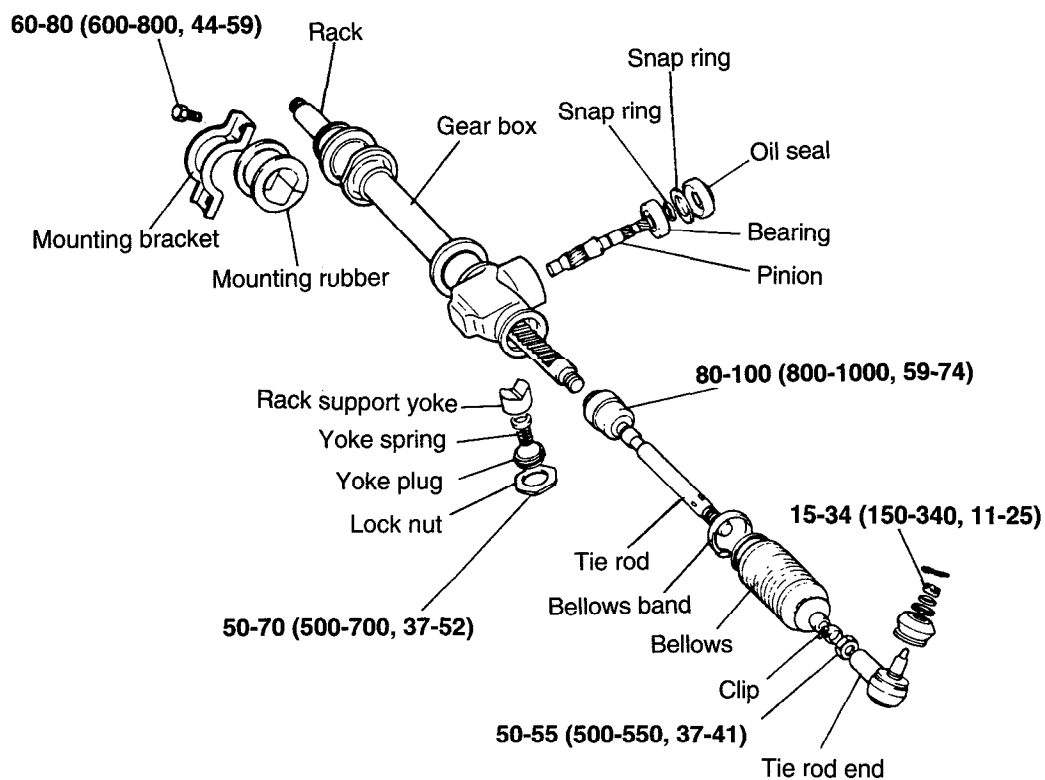

TORQUE : Nm (kg.cm, lb.ft)

## REMOVAL

1. Remove the wheel and tire assembly.
2. Remove the coupling bolt.

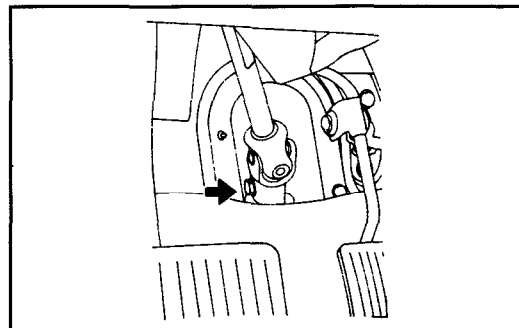

- Remove the tie rods from the knuckle arms, using the Special Tool (09568-31000).

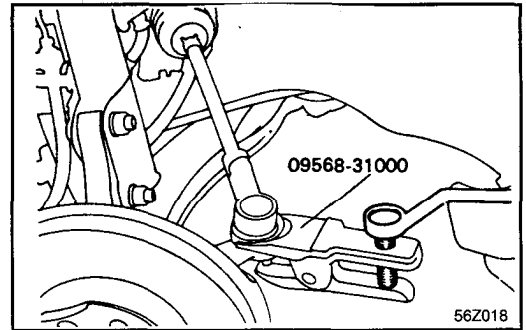

- Remove the rack and pinion assembly from the gear box mounting.

**DISASSEMBLY**

Before disassembly, measure the rack starting force and pinion starting torque in the neutral (straight ahead) position for reference at reassembly.

- Clean the rack and pinion assembly and mount it in a soft-jawed vise.

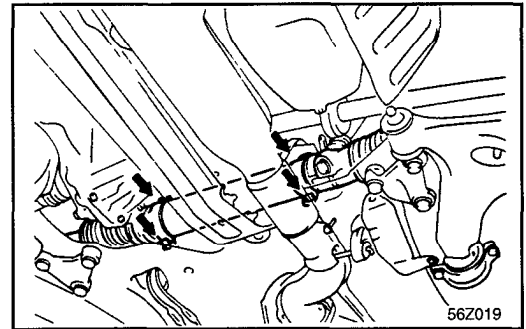

**CAUTION**

When mounting the rack in the vise, wrap a cloth around the rack and be careful not to damage the rack when tightening the vise.

- Remove the tie rod assembly.
- Remove the lock nut from the yoke plug.

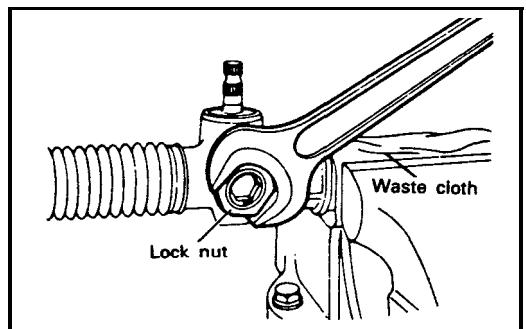

- Using Special Tool (09565-21100), remove the yoke plug.

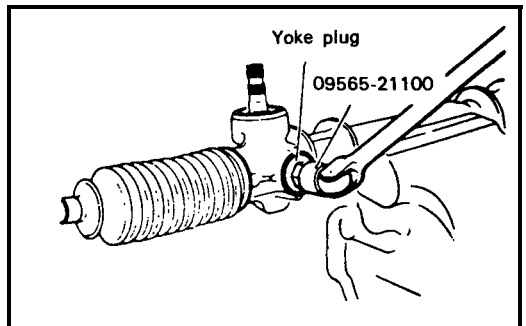

5. Remove the yoke spring, cushion rubber and support yoke from the gear box.

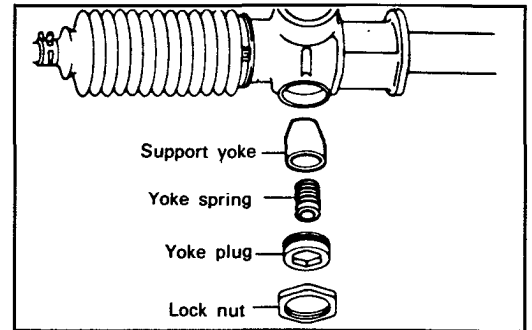

6. Remove the dust cap.  
7. Remove the oil seal from the gear box.

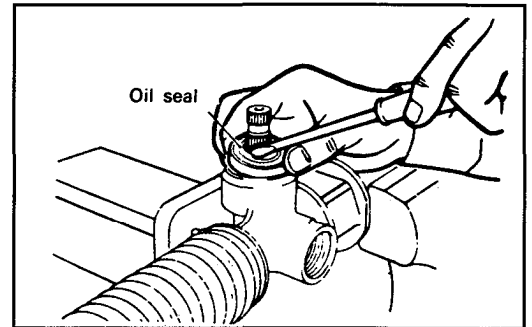

8. Remove the snap ring from the gear box. Remove the pinion together with the bearing.

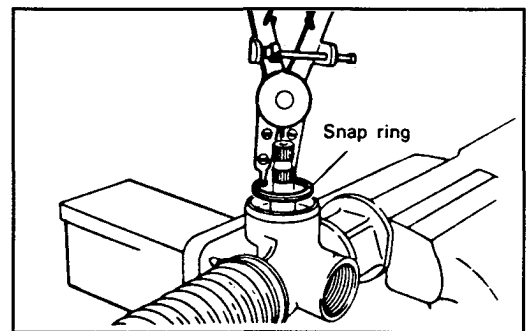

9. Remove the bearing retainer snap ring from the pinion.

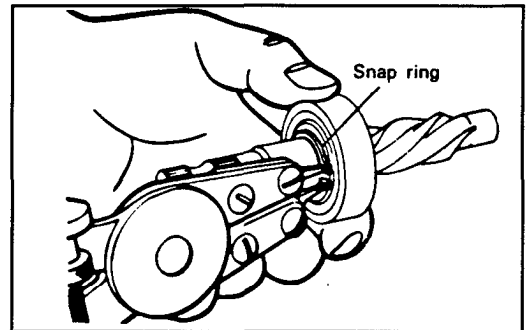

10. Using Special Tool (09565-21000), remove the bearing from the pinion.

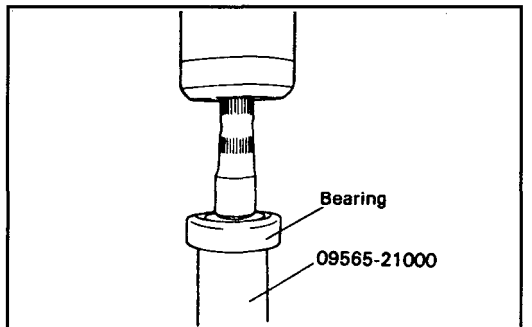

11. Remove the bellows.
12. Using a chisel, unstake the right side rack end nut.

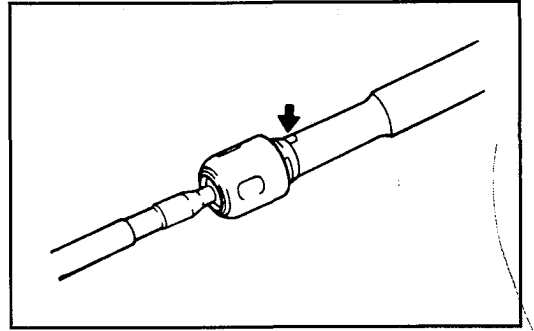

13. Move the rack all the way towards the rack housing and hold the toothed portion of the rack in a soft-jawed vise. Loosen the tie rod end and remove the tie rod assembly from the rack.

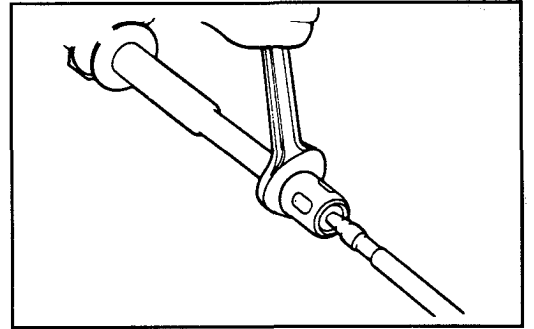

14. Remove the rack from the gear housing.

**CAUTION**

To keep from damaging the bushing with the rack teeth, remove the rack from the left side.

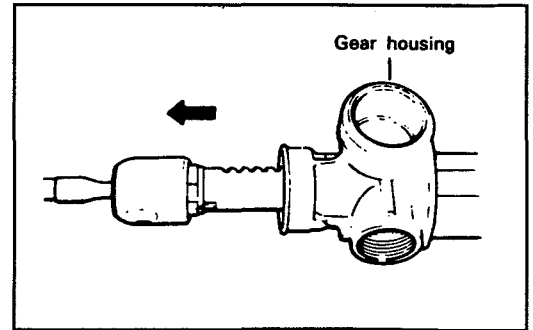

**INSPECTION**

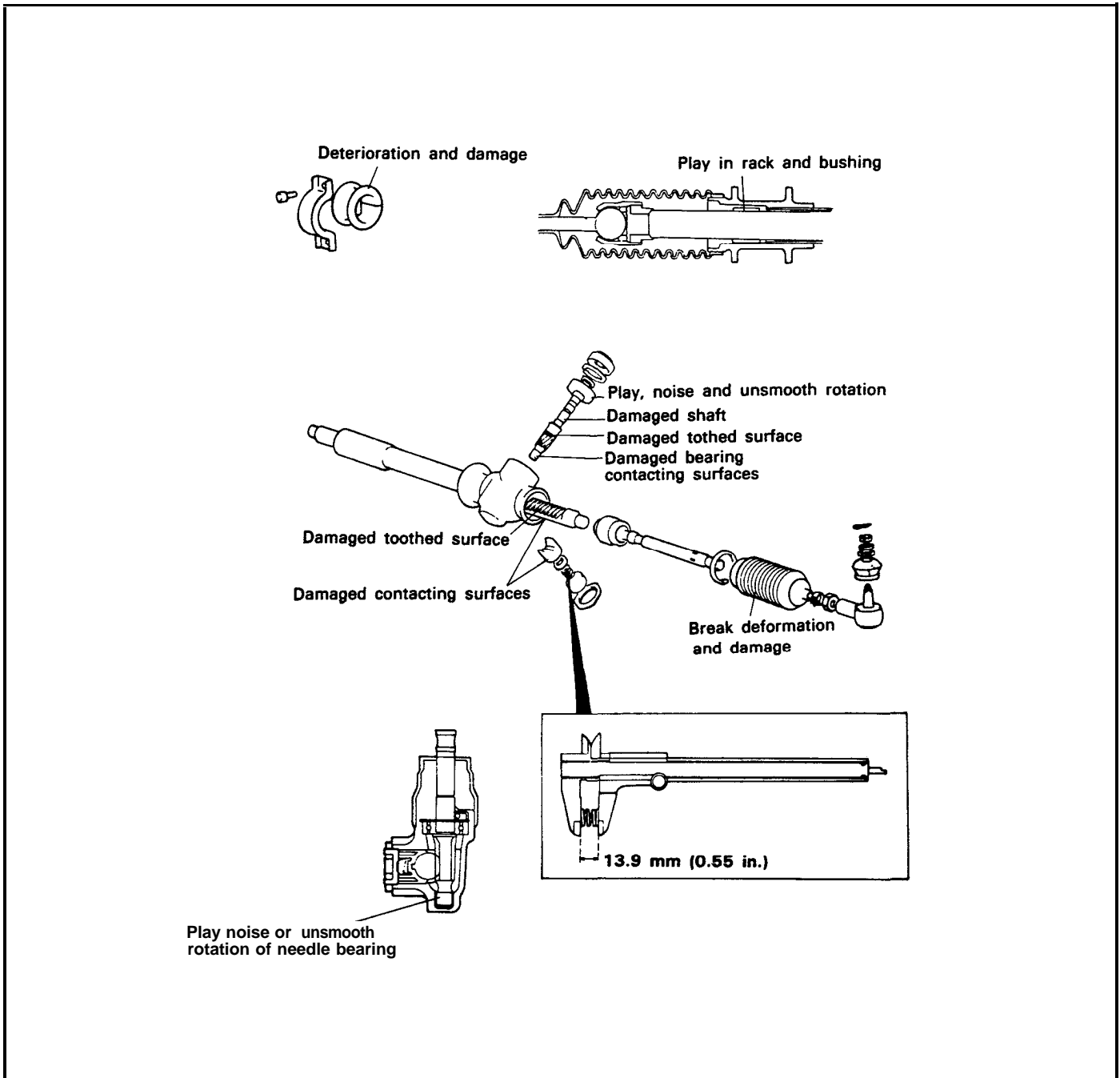

**ASSEMBLY**

1. Prior to reassembly, clean all gear box components in a suitable solvent.
2. Press fit the bearing to the pinion with Special Tool (09565-21000).

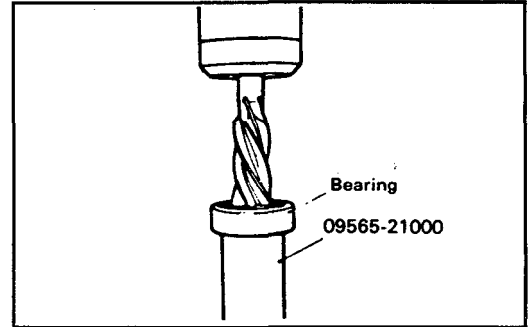

3. Install the snap ring on the pinion.

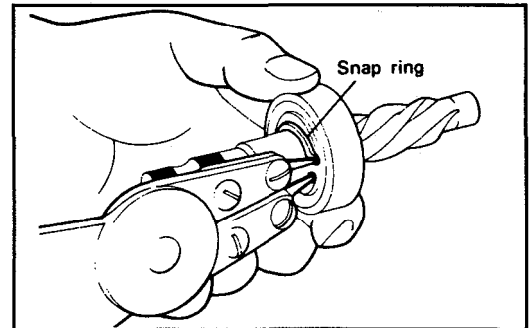

4. Apply grease to the rack, pinion, bushing, needle roller bearing and other moving surfaces.

**CAUTION**

**Do not seal the air passage in the housing bushing with grease.**

---

Recommended grease .....  
 Multipurpose grease SAE J310a, NLGI grade No.2 LP

---

5. After inserting the rack into the gear housing, install the pinion gear in mesh with the rack.

**CAUTION**

- 1) Make sure that the rack is inserted into the gear housing from the left side.
- 2) Wipe away excessive grease.

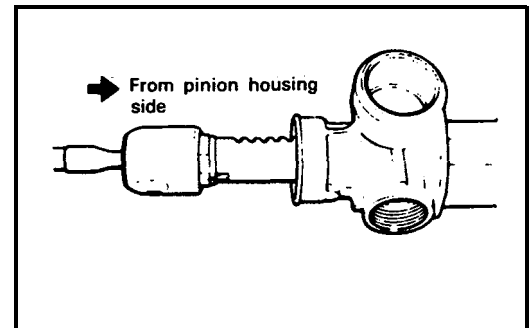

6. Select and install the appropriate type of snap ring to minimize the play in the axial direction on the pinion.

Thickness mm (in.)	Identification color
1.590 (0.063)	Blue
1.665 (0.066)	Whit
1.740 (0.069)	Yellow

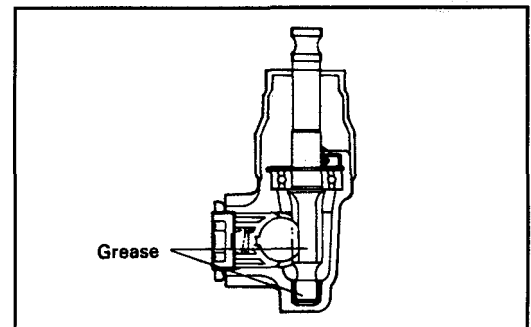

- Apply grease to the lip of the oil seal before installing the oil seal in the gear box.

**NOTE**

Be sure to use a new oil seal.

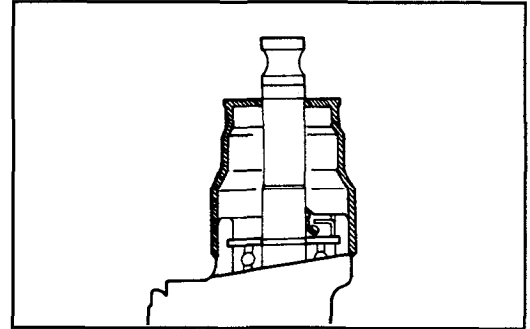

- Install the support yoke, cushion rubber, spring and yoke plug to the pinion gear box.

**CAUTION**

Apply grease to the cupped portion of the support yoke.

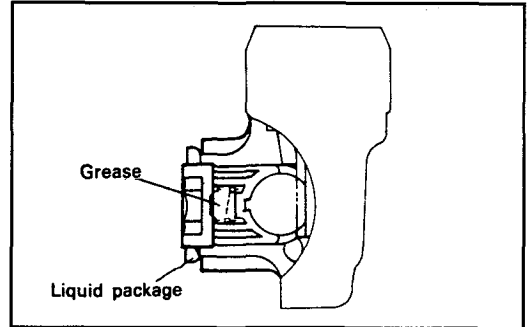

- Adjust the yoke plug, with Special Tool (09565-21000). Tighten the yoke plug to 11 Nm (112 kg.cm, 8 lb.ft) and then back off 30°-60° Secure the yoke plug with the lock nut.

**CAUTION**

- Adjust the yoke plug with the rack in the neutral position.
- Apply a sealer between the lock nut and the housing.

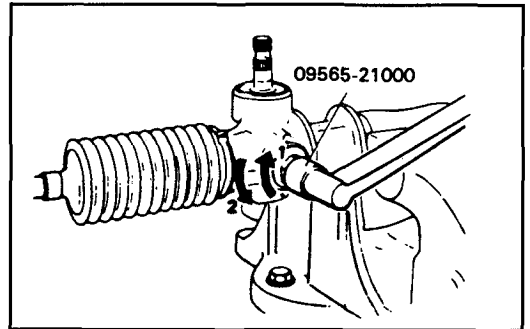

Yoke plug lock nut tightening torque .....  
50-70 Nm (500-700 kg.cm, 37-52 lb.ft)

- Install the tie rod end and bellows. Use a new locking plate and stake each end.
- The combined preload of the pinion (with bellows and grease) should be measured by turning the pinion at a rate of one revolution every 4-6 seconds with Special Tool (99565-11100). The rack starting force should also be measured.

**CAUTION**

The pinion preload should be measured over the full stroke of the rack.

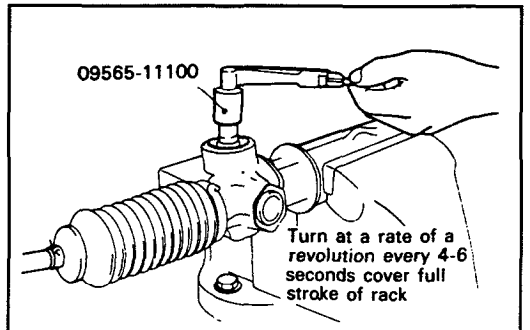

Total pinion preload .....  
± 180° or less from neutral  
0.4-1.1 Nm (4-11 kg.cm, 3.5-9.5 lb.in.)  
± 180° or more from neutral  
0.3-1.6 Nm (3-16 kg.cm, 2.4-14 lb.in.)  
Rack starting force ..... 50-300 N (5-30 kg, 11-66 lb)

- If the measured values are out of specification, replace the cushion rubber and yoke spring and readjust in accordance with step 9.

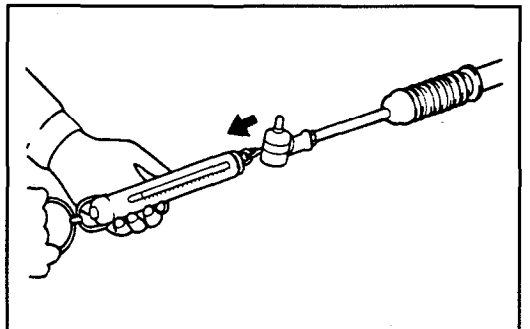

**INSTALLATION**

1. Install the rubber mount on the gear box as shown.

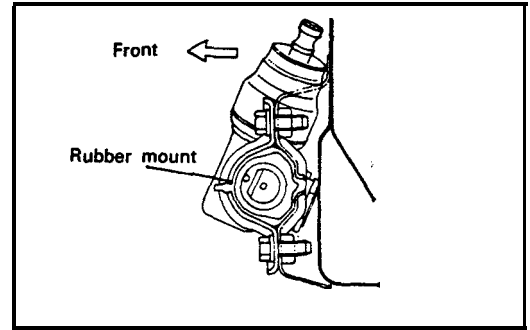

2. Install the pinion in the coupling and install the rack and pinion assembly to the crossmember.

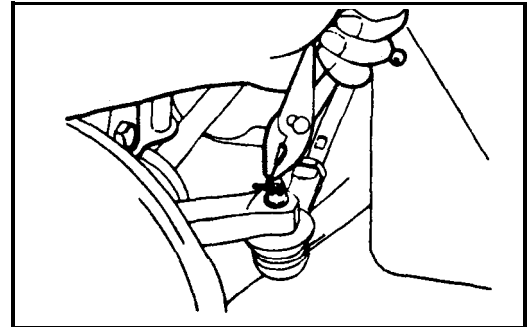

**CAUTION**

- 1) Make sure that the rack and pinion assembly is not tilted or twisted when installed.
- 2) Care must be taken not to apply excessive torque, as it distorts the rack and pinion assembly and affects the steering effort.

3. Tighten the coupling bolt.

---

Joint and pinion tightening torque .....  
 15-20 Nm (150-200 kg.cm, 11-15 lb.ft)

---

4. Install the tie rods on the steering knuckle.

**CAUTION**

**Align the slot of the nut with the split pin hole of the stud and tighten the nut to specifications.**

---

Tie rod ball joint and knuckle arm tightening torque .....  
 15-34 Nm (150-340 kg.cm, 11-25 lb.ft)

---

5. Adjust the wheel alignment.
6. After confirming that the bellows are not twisted, install the clip on the end of the bellows.

## TIE ROD

### COMPONENTS

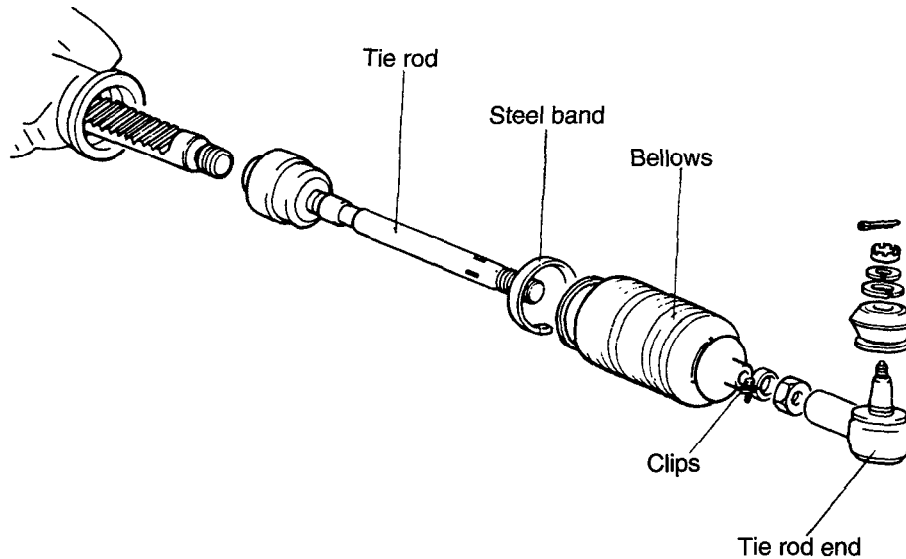

### REMOVAL

Remove the rack and pinion and tie rods from the vehicle as an assembly.

### DISASSEMBLY

1. Mount the rack and pinion assembly in a vise.

#### CAUTION

When mounting the rack in the vise, wrap a cloth around the rack and be careful not to damage the rack when tightening the vise.

2. Cut the bellows mounting band and remove the bellows.

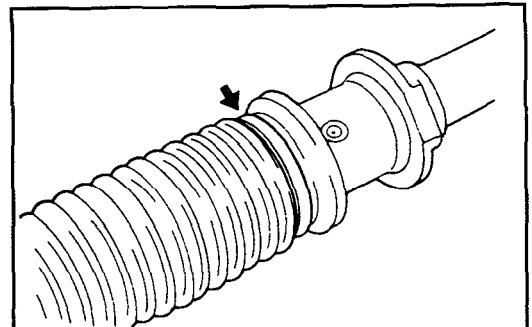

- 3. Unstake the tie rods with a chisel.

**CAUTION**

If the rack is to be removed, remove the left side tie rod end joint from the knuckle.

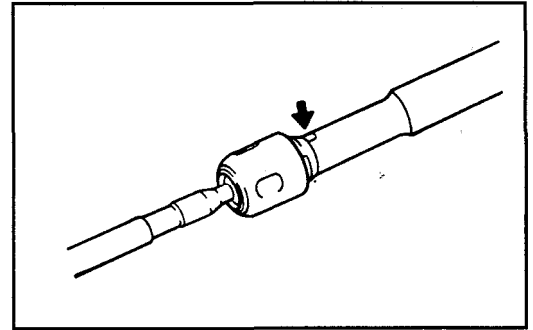

- 4. After moving the rack fully to the right, mount the rack in a soft jawed vise, and remove the left tie rod.
- 5. Remove the right tie rod by the same procedures described in steps (3) and (4).

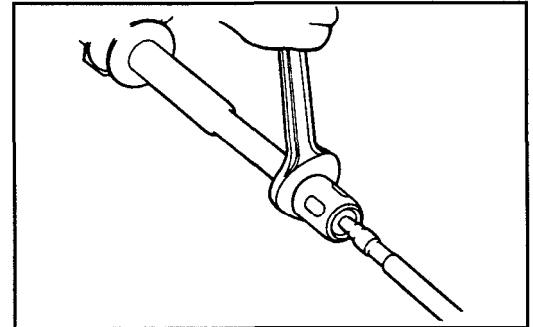

**INSPECTION**

- 1. Damaged or distorted tie rods and ends.
- 2. Damaged or distorted bellows and dust cover.
- 3. Tie rod oscillating torque.

---

Tie rod oscillating torque [Standard value] .....  
 2-5 Nm (20-50 kg.cm, 17-43 lb.in.)

---

- 4. Tie rod ball joint operation and axial play.

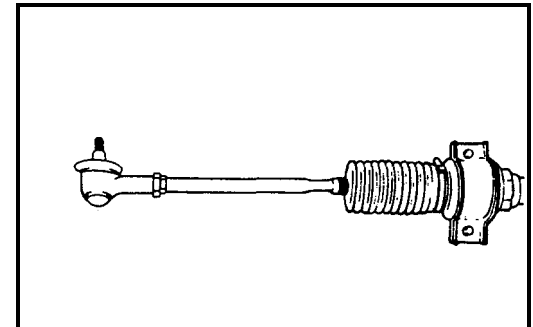

**ASSEMBLY**

- 1. After installing the tie rods to the rack to the specified torque, secure by staking the rack keyway.

---

Tie rod to rack tightening torque  
 80-100 Nm (800-1,000 kg.cm, 59-74 lb.ft)

---

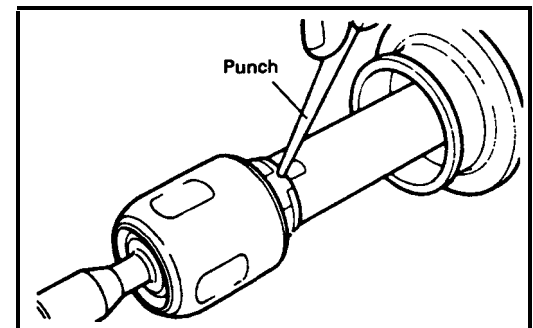

- 2. After installing the bellows on the gear housing, secure with a mounting band.

**CAUTION**

The bellows mounting band should be installed after adjustment of toe-in.

- 3. Measure the rack stroke.

**NOTE**

The full stroke of the rack determines the maximum steering angle.

---

Rack full stroke (lock to lock) . . . . . 132 mm (5.20 in.)

---

- 4. Adjust the length of the tie rods and tighten the lock nut.

---

Tie rod length [Standard value] . . . . .  
 174.3-176.3 mm (7.06-7.14 in.)

Tie rod lock nut tightening torque . . . . .  
**50-55 Nm (500-550 kg.cm, 37-41 lb.ft)**

---

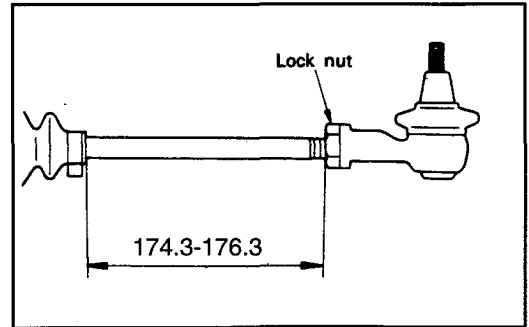
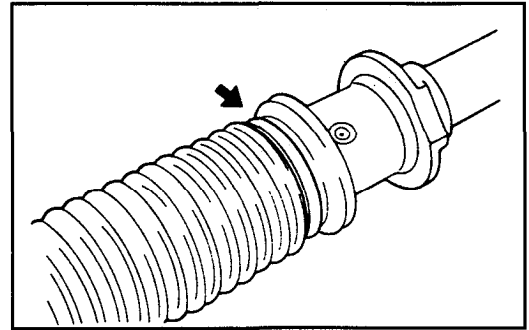

**INSTALLATION**

- 1. Install the rack and pinion and tie rods as an assembly to the vehicle.

POWER STEERING GEAR BOX

COMPONENTS

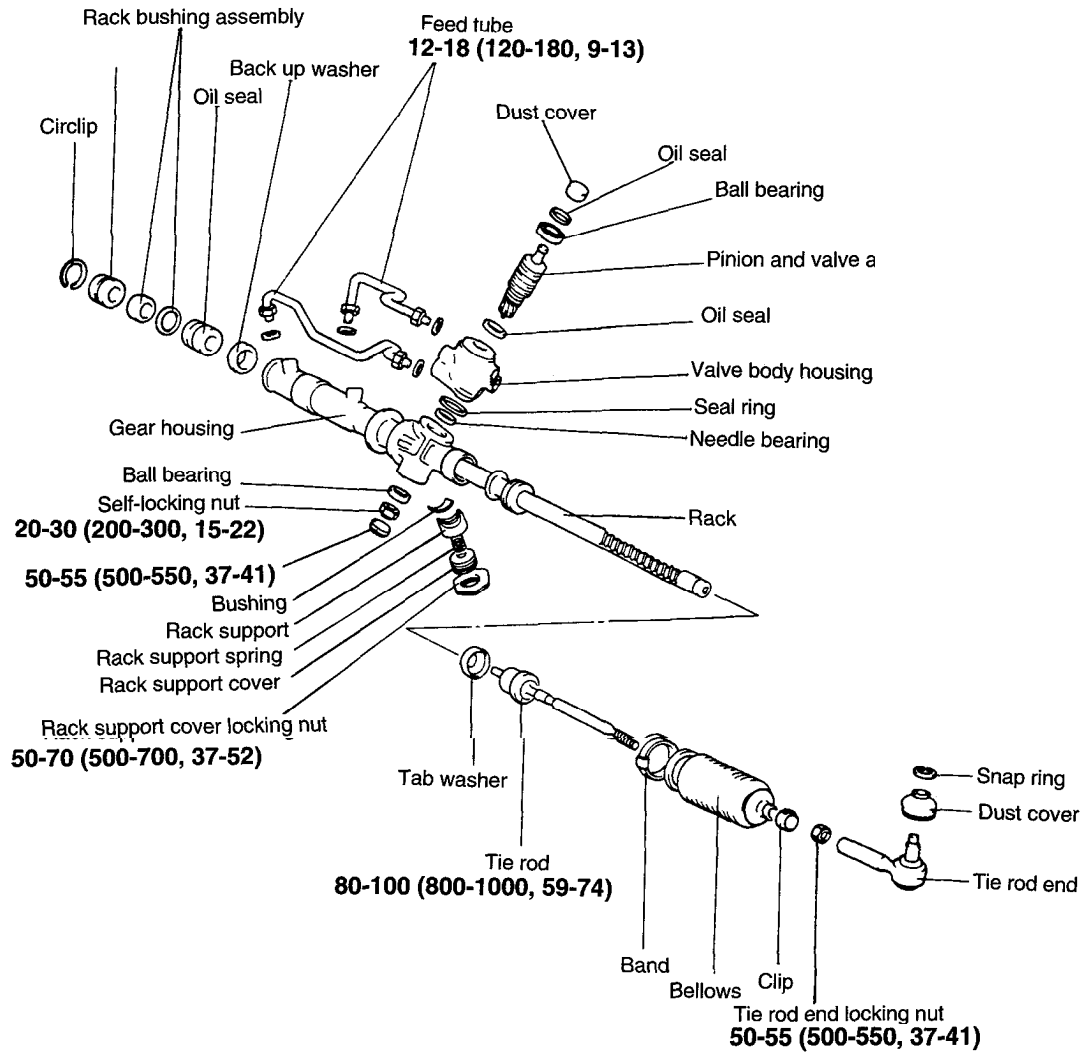

TORQUE : Nm (kg.cm, lb.ft)

**REMOVAL**

1. Using special tool, disconnect the tie rod end from the knuckle.

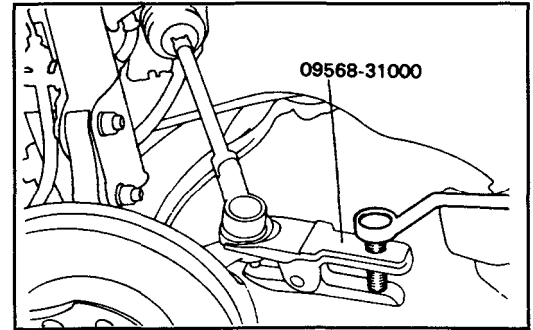

2. Disconnect the shaft assembly from the gear box.

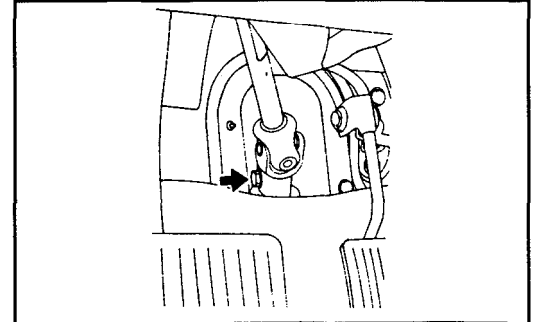

3. Drain the fluid.

4. Disconnect the pressure and return hoses from the gear box.

5. Remove the band from the steering joint cover.

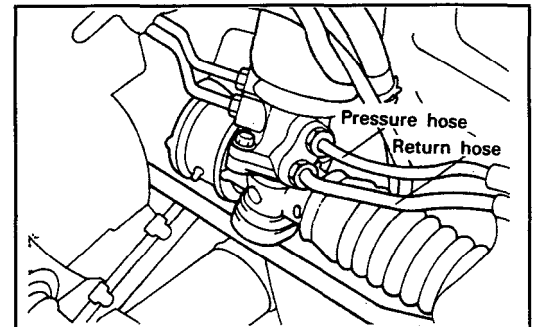

6. Remove the gear box mounting bolts.

7. Pull the gear box out toward the right side of the vehicle.

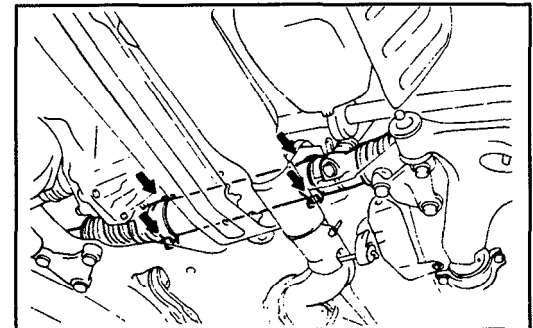
**CAUTION**

When the gear box is to be removed, pull it out carefully and slowly so as not to cause damage to the boots.

**INSPECTION AND ADJUSTMENT PRIOR TO DISASSEMBLY**

Mount the gear box in a soft jawed vise.

**CAUTION**

Do not tighten the vise on the gear housing. Use the mounting section of the rack to secure it in the vise.

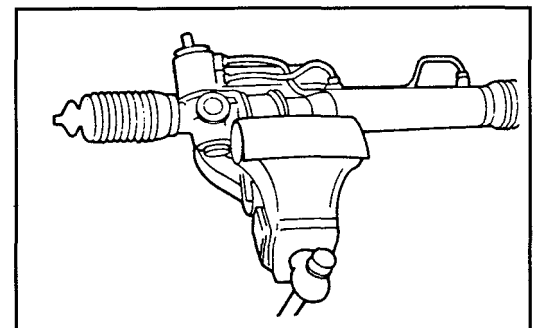

**Total Pinion Preload**

1. Rotate the pinion gear for approximately 4 to 6 seconds for one rotation to confirm the total pinion preload.

---

Total pinion preload [Standard value] . . . . .  
 0.6-1.3 Nm (6-13 kg.cm, 5.2-11.3 lb.in.)

---

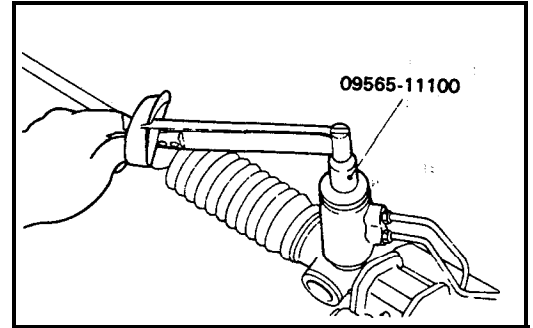

**CAUTION**

**Measure the pinion preload through the entire stroke of the rack.**

2. If the measured value is out of specifications, first adjust the rack support cover, then re-check the total pinion preload.
3. If the rack support cover adjustment does not obtain the total pinion preload, check or replace the rack support cover components.

**Tie Rod Swing Resistance**

1. Give 10 hard swings to the tie rod.
2. Measure the tie rod swing resistance with a spring scale.

---

Tie rod swing resistance [Standard value] .....  
 8-22 N (6-16 lb)  
 [2-5 Nm (20-50 kg.cm, 17-43 lb.in.)]

---

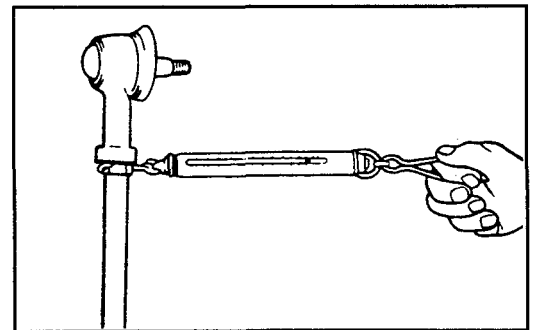

3. If the measured value exceeds the standard value, replace the tie rod assembly.

**NOTE**

**Even if the measured value is below the standard value, a tie rod that swings smoothly without excessive play may be used. If the measured value is below 4.3 N (0.9 lb)[100 Ncm (8.7 lb.in.)], replace the tie rod.**

**Bellows Inspection**

1. Inspect the bellows for damage or deterioration.
2. Make sure the bellows are secured in the correct position.
3. If the bellows are defective, replace them.

**DISASSEMBLY****CAUTION**

Components inside of the TRW power steering gear box should not be repaired or replaced.

If necessary, they will supply a complete gear box assembly for you.

1. Remove the tie rod end from the tie rod.

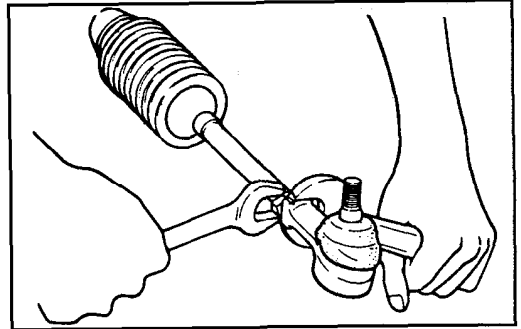

2. Remove the dust cover from the ball joint.

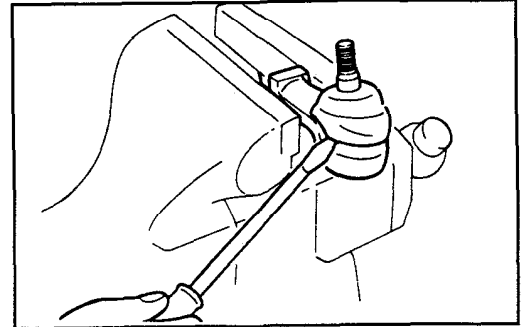

3. Remove the bellows band.

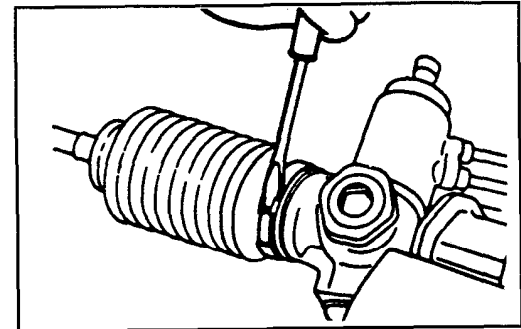

4. Remove the bellows clip.

5. Pull the bellows out toward the tie rod.

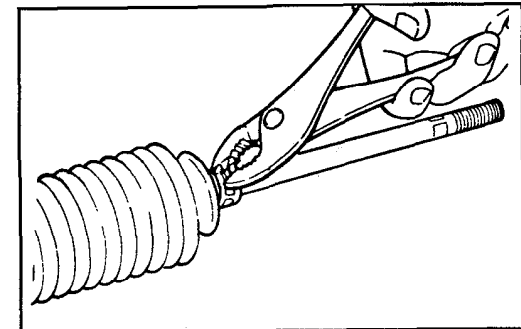
**NOTE**

**Check for rust on the rack when the bellows are replaced.**

6. Remove the feed line from the gear housing.

7. While moving the rack slowly, drain the fluid from the gear housing.

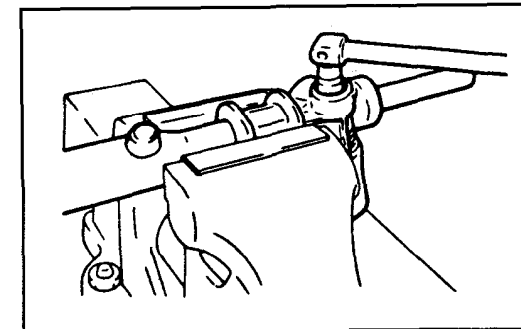

8. Remove the end plug.

9. With the pinion turned clockwise until the rack is locked, remove the self-locking nut.

10. Unstake the tab washer between the tie rod and rack with a chisel.

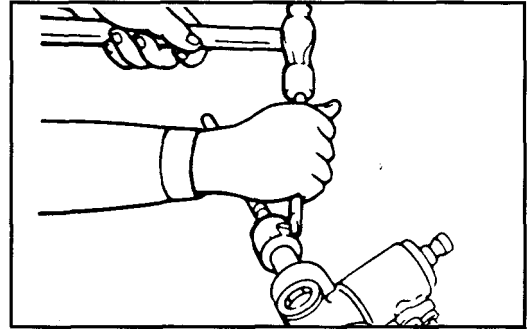

11. Remove the tie rod from the rack.

**CAUTION**

Remove the tie rod from the rack, taking care not to twist the rack.

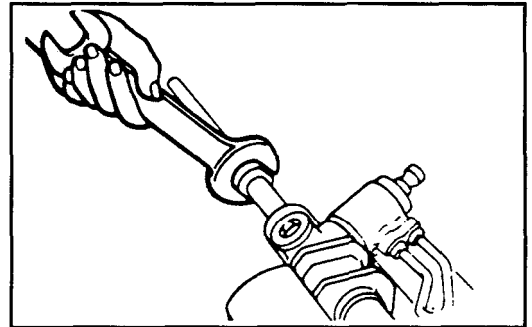

12. Remove the rack support cover locking nut.

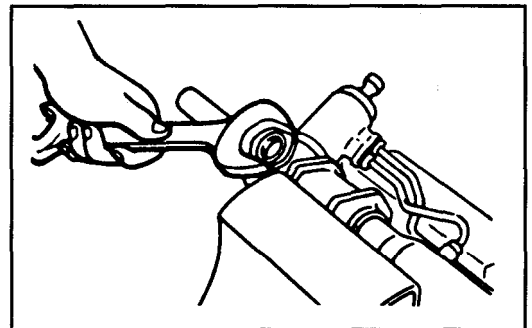

13. Using Special Tool (09565-21100), remove the rack support cover.

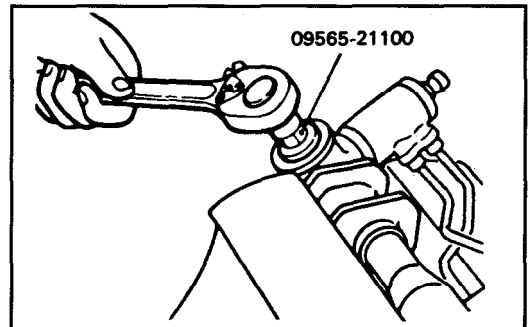

14. Remove the rack support spring, rack support and bushing from the gear box.

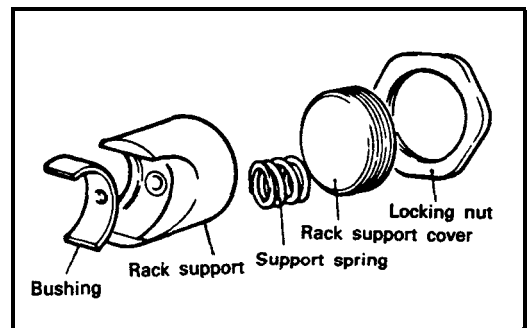

15. Remove the valve body housing by loosening the two bolts.

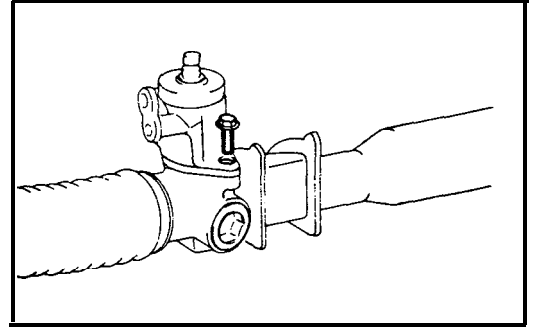

16. Turn the rack stopper clockwise until the end of the circlip comes out of the slot in the gear housing.

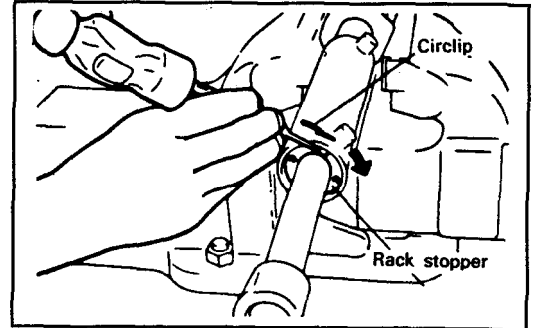

17. When the end of the circlip comes out from the notched hole of the housing rack cylinder, turn the rack stopper counterclockwise and remove the circlip.

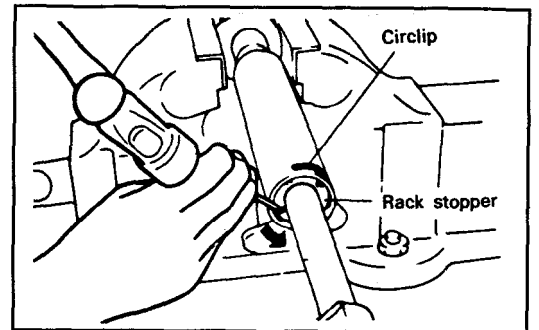

18. Remove the rack stopper, rack bushing and rack from the gear housing by moving it toward the pinion side.

**CAUTION**

**When the rack has been removed, be sure to replace the housing side oil seal.**

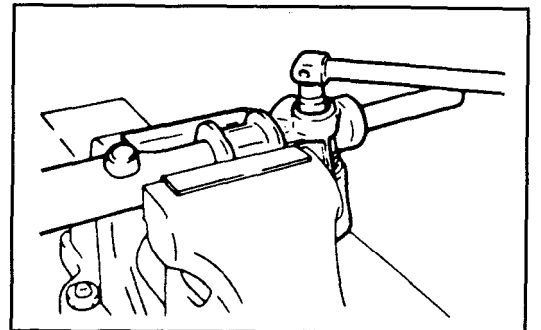

19. Remove the O-ring from the rack bushing.

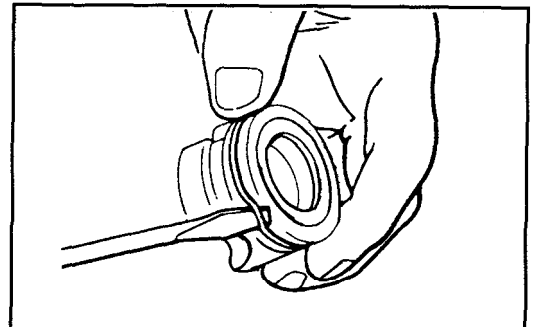

20. Remove the oil seal from the rack bushing.

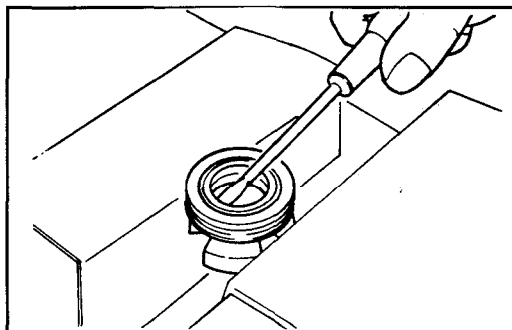

21. Remove the valve body from valve body housing with a soft hammer.

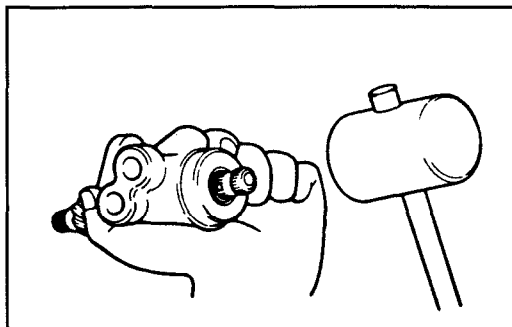

22. Use the special tool (09565-21000) to remove the oil seal and ball bearing from the valve body housing.

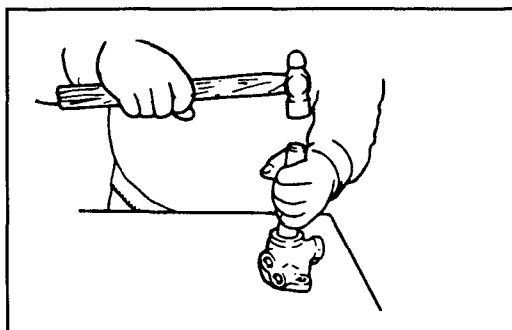

23. Use the special tool (09517-21400) to remove the ball bearing from the gear housing.

**CAUTION**

**Be careful not to damage the pinion valve cylinder inside of the gear housing.**

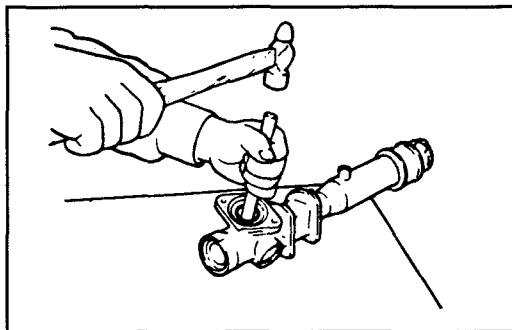

24. Use the special tool (09517-21400) to remove the needle bearing from the gear housing.

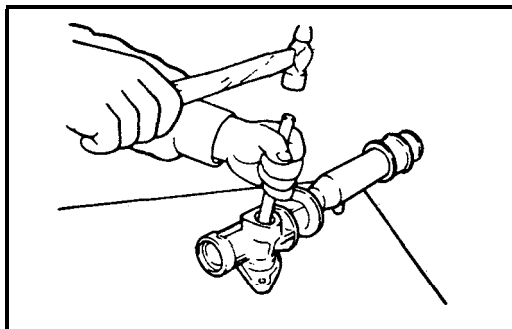

25. Use the special tools (09573-21200, 09555-21000) to remove the back washer and oil seal from the gear housing.

**CAUTION**

Be careful not to damage the rack cylinder inside of the gear housing.

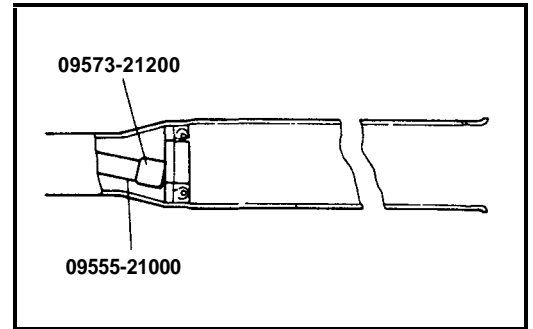

**INSPECTION**

1. Rack

- 1) Rack tooth face damage or wear
- 2) Oil seal contact surface damage
- 3) Rack distortion
- 4) Oil seal ring damage or wear
- 5) Oil seal damage or wear

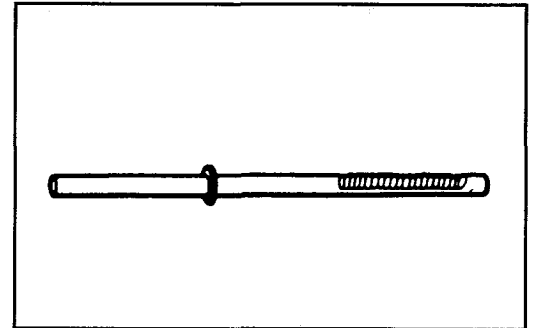

2. Pinion Valve

- 1) Pinion gear tooth face damage or wear
- 2) Oil seal contact surface damage
- 3) Seal ring damage or wear
- 4) Oil seal damage or wear

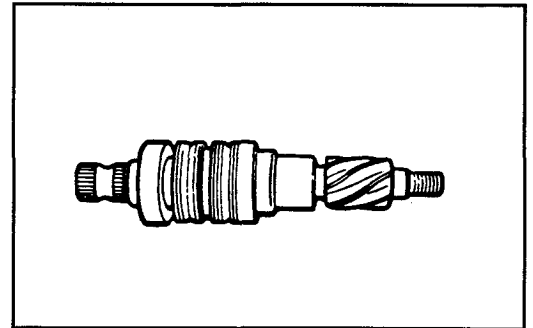

3. Bearing

- 1) Seizure or abnormal noise during bearing rotation.
- 2) Excessive play
- 3) Missing needle bearings

4. Others

- 1) Damage of the gear housing cylinder bore
- 2) Boot damage or deterioration

**ASSEMBLY**

1. Apply the specified oil to the entire surface of the rack oil seal.

Recommended fluid .....  
 Automatic transaxle fluid DEXRON®II type

2. Install the backup washer and oil seal to the specified position in the gear housing.

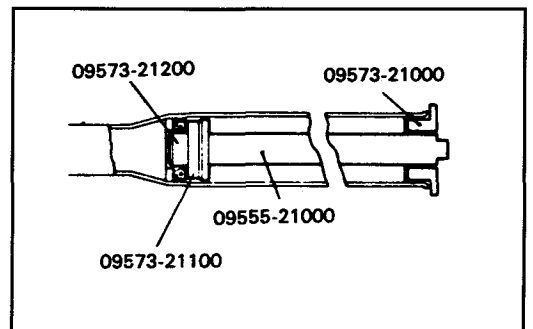

- 3. Apply the specified grease to the entire surface of the needle bearing.

Recommended grease .....  
 Multipurpose grease SAE J310, NLGI No.2

- 4. Set the scribed side of the needle bearing in the Special Tool (09432-21600) and install it into the gear housing (until the special tool contacts the gear housing).

**CAUTION**  
 Note the direction of the needle bearing.

- 5. Apply the specified grease to the ball bearing and install using the special tool (09222-21100).

Recommended grease .....  
 Multipurpose grease SAE J310, NLGI No.2

**CAUTION**  
 Always use a new bearing

- 6. Apply the specified oil to the entire surface of the rack bushing oil seal.

Recommended fluid .....  
 Automatic transaxle fluid DEXRON®II type

- 7. Install the oil seal in the rack bushing.
- 8. Apply the specified oil to the entire surface of the O-ring and install it in the rack bushing.

- 9. Apply the specified grease to the rack teeth.

Recommended grease .....  
 Multipurpose grease SAE J310, NLGI No.2

**CAUTION**  
 Do not plug the vent hole in the rack with grease.

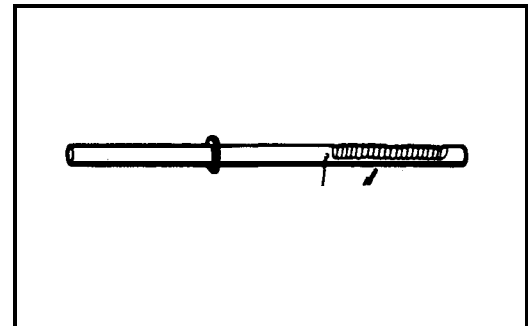
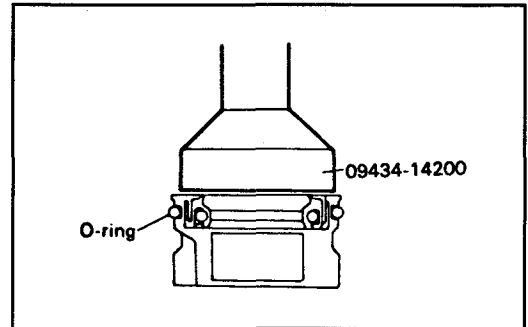
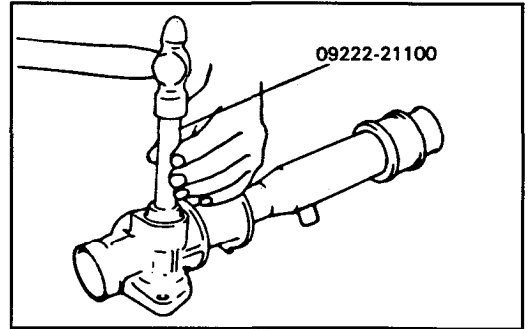
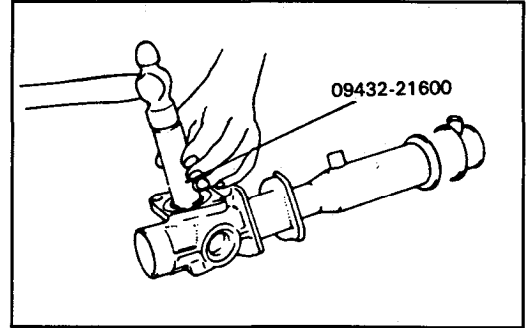

10. Insert the rack into the gear housing.  
Install the rack bushing and rack stopper.

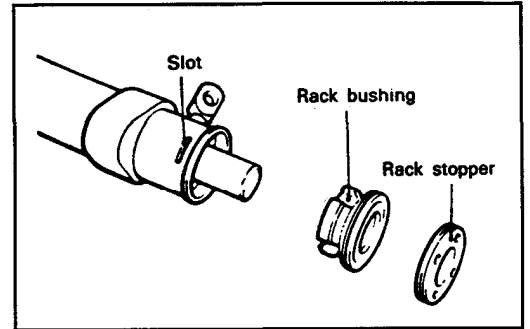

11. Push in the rack stopper until the circlip groove of the rack stopper is aligned with the notched hole of the rack housing. Install the circlip while turning the rack stopper.

**CAUTION**

The circlip end should not be visible through the notched hole of the rack housing.

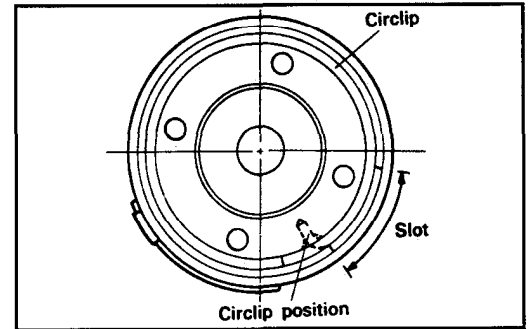

12. Using Special Tool (09432-21600) install the oil seal and the ball bearing in the valve body.

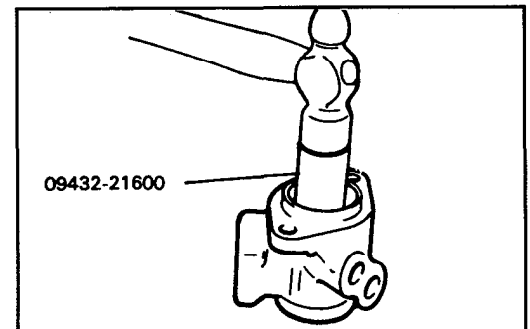

13. Apply the specified oil and grease to the pinion valve assembly and install in the gear housing assembly.

Recommended fluid .....  
Automatic transaxle fluid DEXRON®II type

Recommended grease .....  
Multipurpose grease SAE J310, NLGI No.2

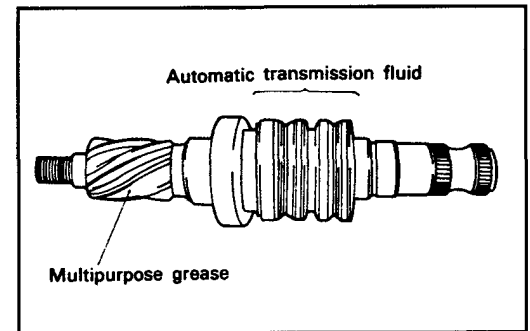

14. Apply the specified oil and then use the Special Tool (09434-14200) to install the seal in the valve body housing.

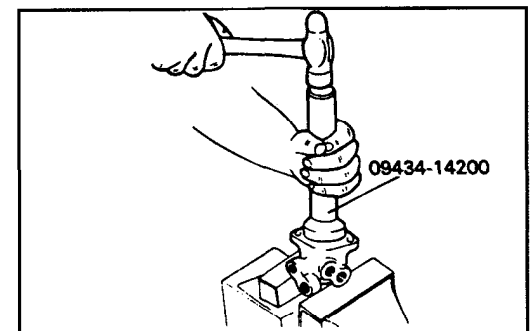

15. Install the valve body assembly with the seal ring to the gear box.

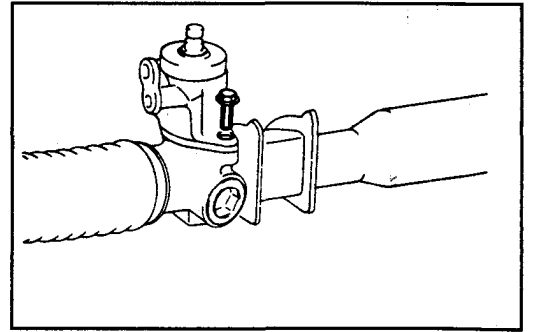

16. Install the tab washer and the tie rod and stake the tab washer end at two points over the tie rod.

**CAUTION**

- 1) Align the tab washer pawls with the rack grooves.
- 2) Always use a new tab washer.

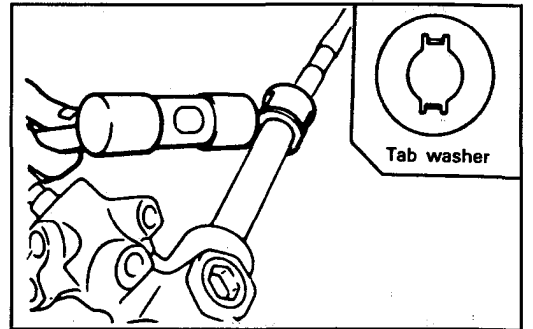

17. With the pinion turned all the way clockwise, tighten the self-locking nut.

**CAUTION**

Always use a new nut.

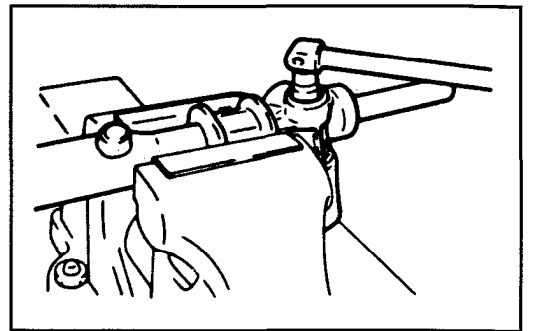

18. Apply semi-drying sealant to the threaded section of the end plug and tighten to the specified torque.

Tightening torque .....  
**50-70 Nm (500-700 kg.cm, 37-52 lb.ft)**

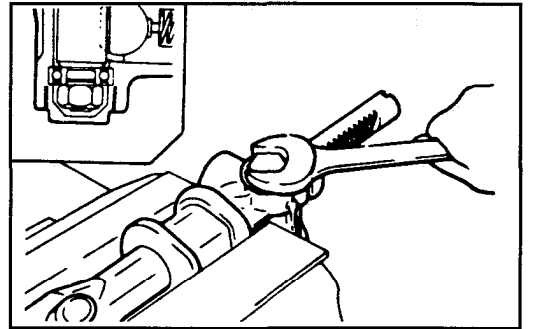

19. Stake the end plug at two points on its circumference with a punch.

20. Install the bushing, rack support, rack support spring and rack support cover in the order shown. Apply semi-drying sealant to the threaded section of the rack support cover before installation.

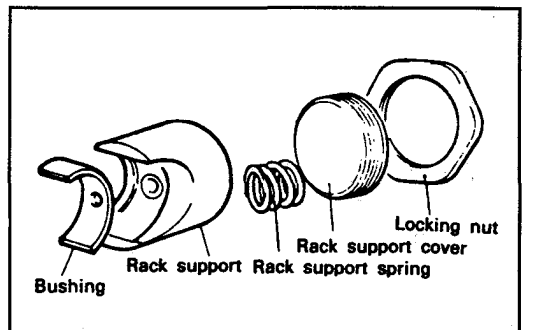

- With the rack placed in the center position, attach the rack support cover to the gear housing. Tighten the rack support cover within the range of 20-25 Nm (200-250, kg.cm, 14.5-18 lb.ft), using the Special Tool (09565-21100). Loosen the rack support cover approximately 10°, and tighten the locking nut to the specified torque

Tightening torque .....  
 50-70 Nm (500-700 kg.cm, 37-52 lb.ft)

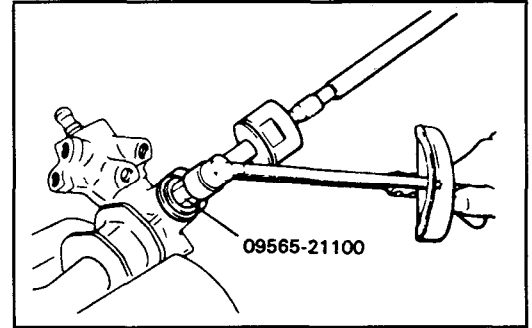

- Tighten the feed tube to the specified torque and install the mounting rubber using adhesive.
- Apply the specified grease to the bellows mounting position (fitting groove) of the tie rod.

Recommended grease .....  
 Multipurpose grease SAE J310, NLGI No.2

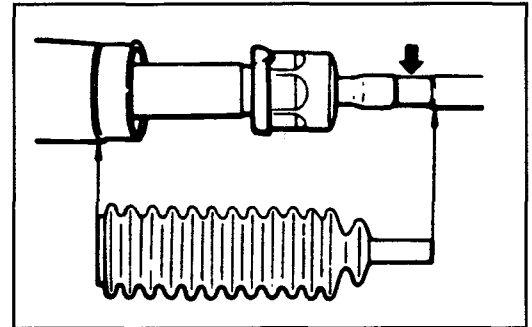

- Install the attaching band to the bellows.

**CAUTION**  
 When the bellows are installed, a new band must be used.

- Install the bellows in position, taking care not to twist it.
- Fill the dust cover inner side and lip with the specified multi-purpose grease, and place the dust cover in position with the clip ring attached in the groove of the tie rod end.

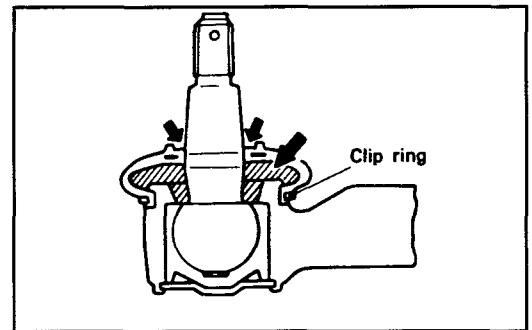

- Install the tie rods so that the length of the left and right tie rods are equal.

Tie rod length [Standard value] .....  
 174.3-176.3 mm (6.86-6.94 in.)

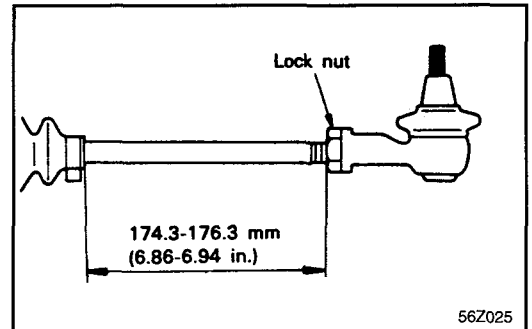

- Confirm the total pinion preload.

**INSTALLATION**

- Install with the projection on the mounting rubber of the gear housing aligned with the holes in the clamp and gear housing bracket.
- Apply adhesive to the cylinder side mounting rubber so that its slitted part will not open.
- Check that there are no oil leaks.
- Confirm the steering wheel rotates smoothly.
- Adjust the toe-in.
- Install all parts with reference to the torque specification.

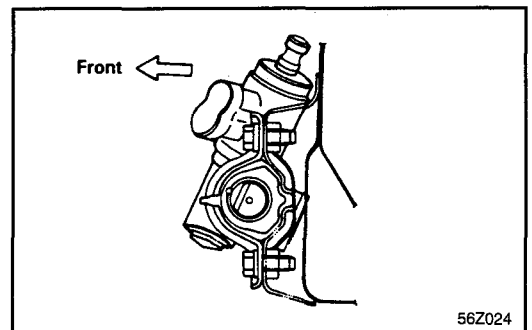

POWER STEERING OIL PUMP

COMPONENTS

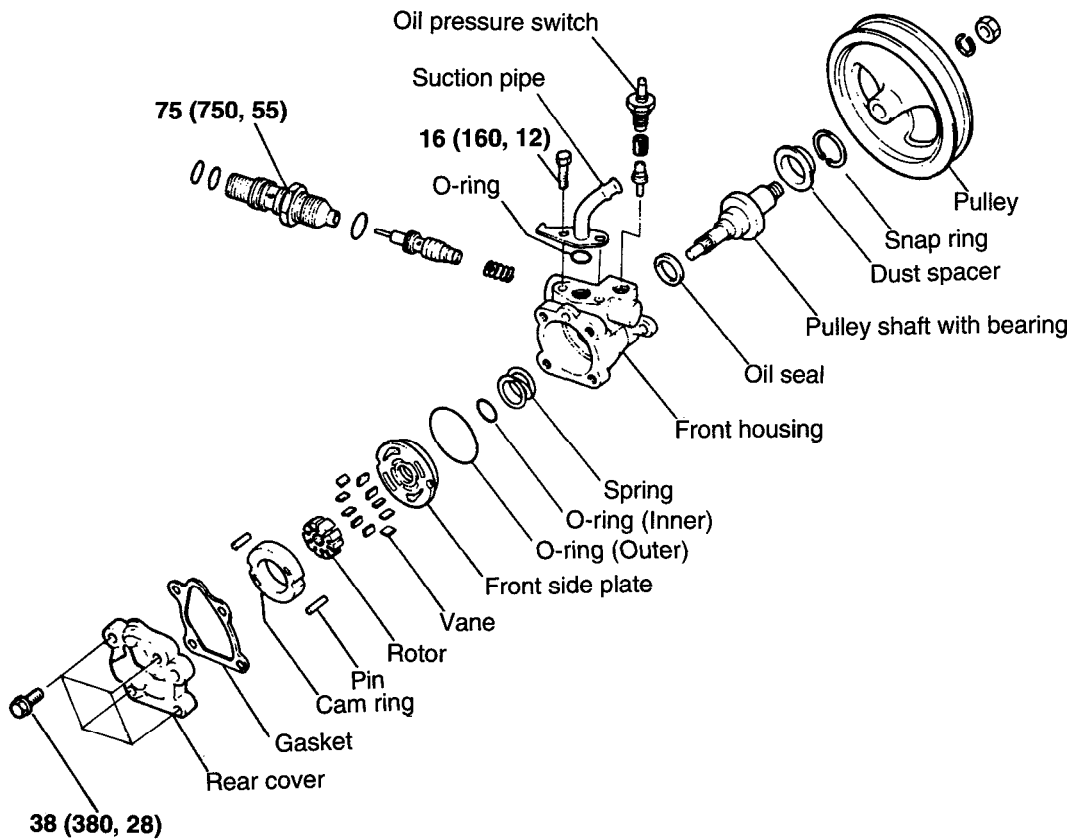

TORQUE : Nm (kg.cm, lb.ft)

REMOVAL

1. Remove the pressure hose from the oil pump.
2. Disconnect the suction hose from the suction connector and drain the fluid into a container.

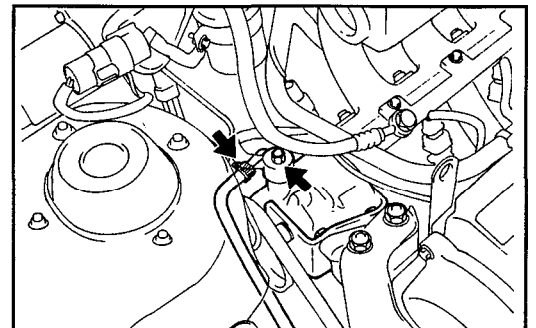

3. Loosen the oil pump mounting bolts to remove the V-belt.
4. Remove the oil pump bracket mounting bolts and disconnect the pressure switch connector.

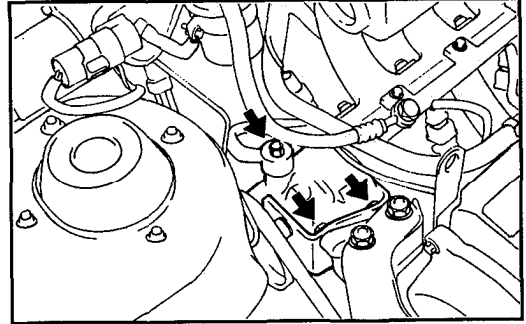

## DISASSEMBLY

1. Remove the suction connector and the O-ring from the oil pump.

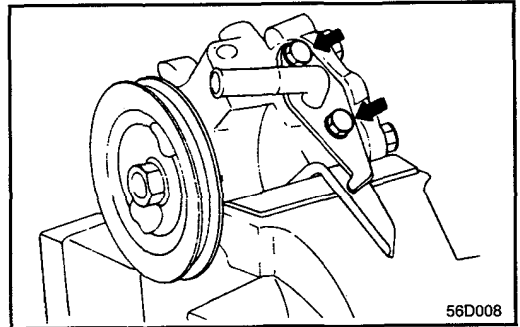

2. Remove the rear cover with the gasket and pins.
3. Remove the cam ring.
4. Remove the rotor and vanes.
5. Remove the front side plate.

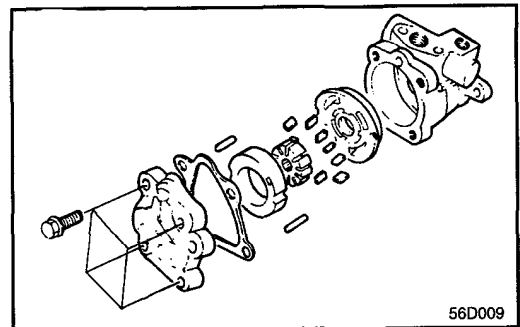

6. Remove the inner and outer O-ring.
7. Remove the spring.

### NOTE

When assembling, use a new gasket and O-ring.

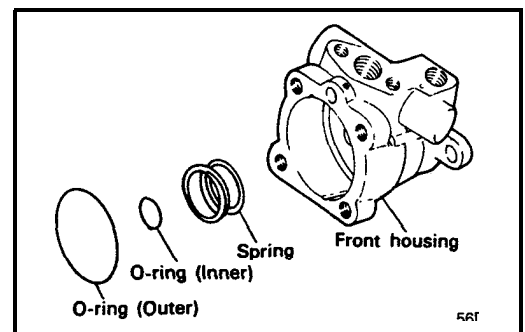

8. Remove the pulley nut with the spring washer.
9. Pull off the pulley and the woodruff key.

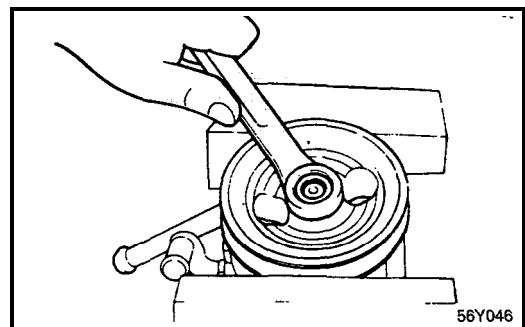

10. Remove the snap ring using snap ring pliers.
11. Drive out the pulley shaft with the bearing.  
If necessary, use plastic hammer.

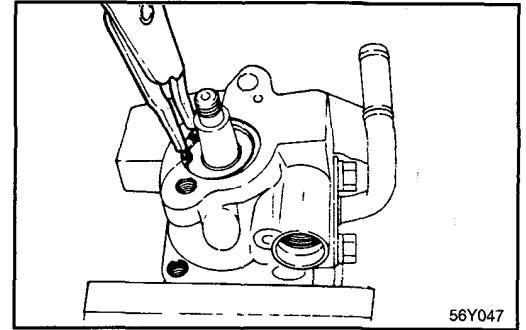

12. Remove the oil seal from the oil pump body.

**NOTE**

When assembling, use a new oil seal.

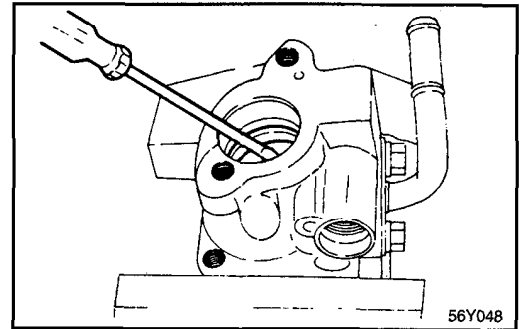

13. Remove the guide bracket and nut.
14. Remove the connector from the oil pump body, and take out the flow control valve and the flow control spring.
15. Remove the O-ring from the connector.

**CAUTION**

Do not disassemble the flow control valve.

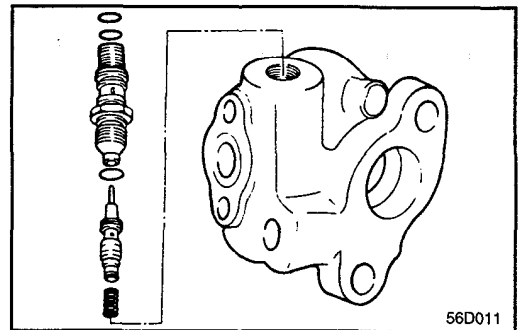

16. Remove the oil pump switch.
17. Take out the spring and the spool.
18. Remove the O-ring from the oil pump switch.

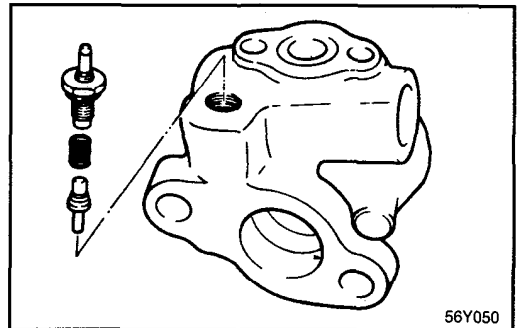
**INSPECTION**

1. Clean all disassembled parts with suitable cleaning solvent.
2. If any inside parts of the oil pump have been damaged, replace the pump as an assembly.
3. If the pulley is cracked or deformed, replace it.
4. If oil leaks from around pulley shaft oil seal, replace the oil seal.
5. If the serrations of the pulley or pulley shaft are deformed or worn, replace them.

**ASSEMBLY**

1. Install the oil pump switch.
2. Install the flow control valve spring, valve and connector in the pump body.

**NOTE**

**Apply a thin coat of A.T.F. to all the replaced parts including the oil seal and the O-ring.**

3. Install the guide bracket and nut.
4. Using special tool (09222-32100), install the oil seal into the pump body.

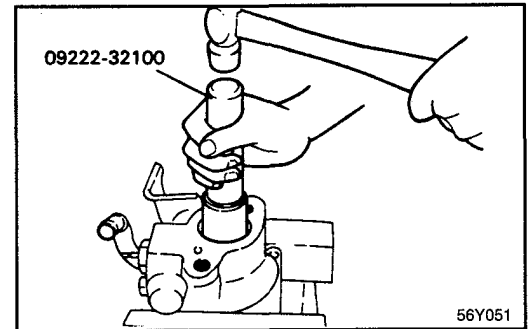

5. Gently insert the shaft assembly and install the snap ring.
6. Install the pump pulley with woodruff key in place.

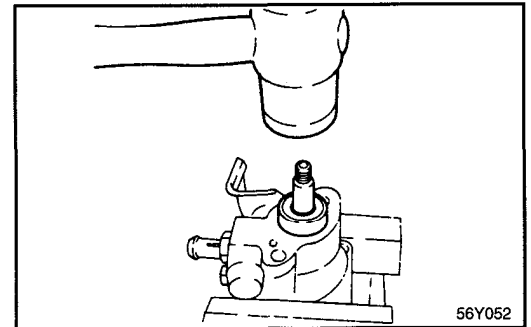

7. Install the spring and the inner and outer O-rings.
8. Install the front side plate.

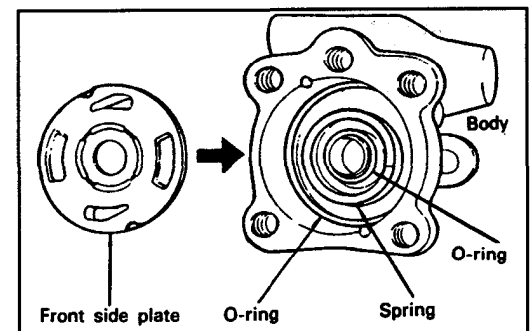

9. Insert the pins into the pin grooves of front housing, then install the cam ring, paying attention to its direction.

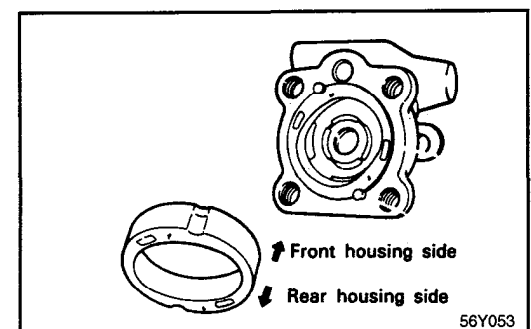

10. Install the rotor with its punch marked side facing towards the front side plate.
11. Install the vane plates with the round end facing outward.

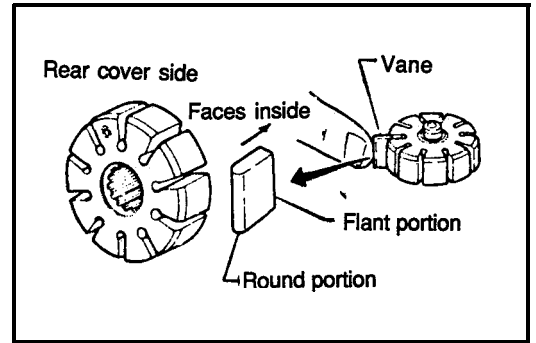

12. Install the gasket and the rear cover.
13. Tighten the suction connector.

**INSTALLATION**

1. Install the oil pump to the oil pump bracket.
2. Install the suction hose.
3. Install the V-belt and adjust the V-belt tension.
4. Connect the pressure hose to the oil pump, and the return hose to the oil reservoir.

**NOTE**

**Install the hoses so that they are not twisted and they do not come in contact with any other parts.**

6. Replenish the fluid.

---

Recommended fluid .....  
 Specified automatic transmission fluid

---

6. Bleed the system.
7. Check the oil pump pressure.
8. Install parts by reference to the torque specification.

## POWER STEERING HOSES

## COMPONENTS

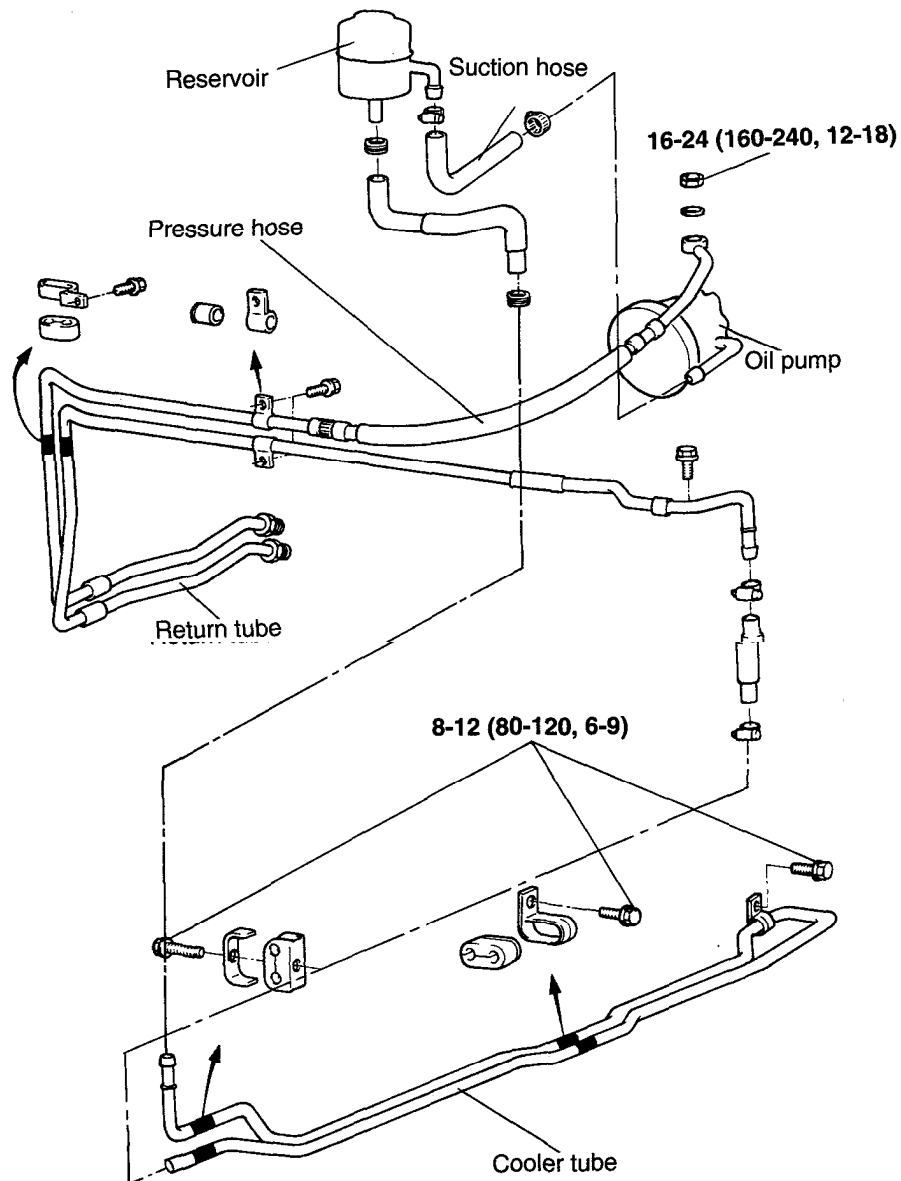

TORQUE : Nm (kg.cm, lb.ft)

## REMOVAL (Return tube)

1. Drain the fluid.
2. Disconnect the return hose from the oil reservoir.
3. Remove the clip which secures the return tube to the vehicle body.
4. Disconnect the return tube from the gear box.

**INSPECTION**

1. Inspect the hoses for damage or deterioration.
2. Confirm that there is no interference between the hoses and any other parts.

**INSTALLATION**

Install all parts to the torque specifications.

