

MANUAL TRANSAXLE

Return To Main Table of Contents

GENERAL	2
MANUAL TRANSAXLE CONTROL	11
SHIFT LEVER ASSEMBLY	13
MANUAL TRANSAXLE	14
MANUAL TRANSAXLE ASSEMBLY	17
INPUT SHAFT	32
OUTPUT SHAFT	36
SHIFT FORK AND CONTROL SHAFT ASSEMBLY.....	41
DIFFERENTIAL	42
SPEEDOMETER DRIVEN GEAR ASSEMBLY	45

GENERAL**SPECIFICATIONS**

Model		M5AF	
Type		N/A	T/C
Gea ratio	First	2.462	-
	Second	2.053	-
	Third	1.370	-
	Fourth	1.031	-
	Fifth	0.838	0.878
	Final	3.250	3.250
Speedometer gear ratio (driven/drive)		31/36	

SERVICE STANDARD

Standard value		
Input shaft bearing end play		0.00-0.05
Output shaft bearing end play		0.15-0.20
Differential bearing end play		0.25-0.30

LUBRICANTS AND GREASE

	Recommended lubricant	Quantity
Transaxle gear oil lit (U.S. qts., Imp. qts.)	Hypoid gear oil, SAE 75W/85W, API-GL4	2.15 (2.25, 1.95)
Transaxle input shaft spline	MOLYWHITE TA NO.2	As required
Transaxle oil seal lip	RETINAX AM, MOLYTEX GREASE EP 2	As required

SEALANTS AND ADHESIVES

	Recommended sealants and adhesives	Quantity
Transaxle case and clutch housing alignment surface	THREE BOND 1216	As required
Transaxle case and rear cover alignment surface	THREE BOND 1216	As required
Bearing retainer bolt (flush bolt only)	THREE BOND 1303	As required

SNAP RING FOR ADJUSTMENT AND SPACER



Part Name	Clearance of bearing side	Selection thickness	Identification symbols
Input bearing spacer adjusting layer (For adjustment of input shaft bearing end play)	1.27-1.30	1.25	25
	1.30-1.33	1.28	28
	1.33-1.36	1.31	31
	1.36-1.39	1.34	34
	1.39-1.42	1.37	37
	1.42-1.45	1.40	40
	1.45-1.48	1.43	43
	1.48-1.51	1.46	46
	1.51-1.54	1.49	49
	1.54-1.57	1.52	52
	1.57-1.60	1.55	55
	1.60-1.63	1.58	58
	1.63-1.66	1.61	61
	1.66-1.69	1.64	64
	1.69-1.72	1.67	67
	1.72-1.75	1.70	70
	1.75-1.78	1.73	73
	1.78-1.81	1.76	76
	1.81-1.84	1.79	79
	1.84-1.87	1.82	82
1.87-1.90	1.85	85	
1.90-1.93	1.88	88	
Output bearing spacer adjusting layer (For adjustment of output bearing end play)	1.24-1.27	1.43	43
	1.27-1.30	1.46	46
	1.30-1.33	1.49	49
	1.33-1.36	1.52	52
	1.36-1.39	1.55	55
	1.39-1.42	1.58	58
	1.42-1.45	1.61	61
	1.45-1.48	1.64	64
	1.48-1.51	1.67	67
	1.51-1.54	1.70	70
	1.54-1.57	1.73	73
	1.57-1.60	1.76	76
	1.60-1.63	1.79	79
	1.63-1.66	1.82	82
	1.66-1.69	1.85	85
	1.69-1.72	1.88	88
	1.72-1.75	1.91	91
	1.75-1.78	1.94	94
	1.78-1.81	1.97	97
	1.81-1.84	2.00	00
1.84-1.87	2.03	03	
1.87-1.90	2.06	06	
1.90-1.93	2.09	09	
1.93-1.96	2.12	12	

Part Name	Clearance of bearing side	Selection thickness	Identification symbols
Spacer adjusting layer (For adjustment of differential bearing end paly)	0.51-0.54	0.80	80
	0.54-0.57	0.83	83
	0.57-0.60	0.86	86
	0.60-0.63	0.89	89
	0.63-0.66	0.92	92
	0.66-0.69	0.95	95
	0.69-0.72	0.98	98
	0.72-0.75	1.01	01
	0.75-0.78	1.04	04
	0.78-0.81	1.07	07
	0.81-0.84	1.10	10
	0.84-0.87	1.13	13
	0.87-0.90	1.16	16
	0.90-0.93	1.19	19
	0.93-0.96	1.22	22
	0.96-0.99	1.25	25
	0.99-1.02	1.28	28

TIGHTENING TORQUE

	Nm	kg.cm	lb.ft
Shift cable and select cable to body	12-15	120-150	9-11
Shift lever assembly to body	12-15	120-150	9-11
Shift lever to lever (A)	19-28	190-280	13-20
Lever (A) to bracket assembly	19-28	190-280	13-20
Clutch release cylinder mounting bolts	15-22	150-220	11-16
Clutch tube flare nut	13-17	130-170	9-12
Shift cable and select cable to transaxle	15-22	150-220	11-16
Starter motor mounting bolts	27-34	270-340	20-25
Transaxle mount bracket to transaxle	60-80	600-800	43-58
Transaxle mount bracket to body	90-110	900-1100	65-80
Bell housing cover mounting bolts	8-10	80-100	6-7
Transaxle mounting bolts	43-55	430-550	32-39
Rear cover bolt	8-11	80-110	6-8
Backup light switch	30-35	300-350	22-25
Poppet spring plug	25-30	250-300	18-22
Speedometer sleeve bolt	3-5	30-50	2-4
Input shaft lock nut	140-160	1400-1600	102-115
Output gear lock nut	140-160	1400-1600	102-115
Reverse idler gear shaft bolt	43-55	430-550	32-39
Transaxle case tightening bolt	25-28	250-280	18-20
Stopper bracket bolt	15-22	150-220	11-15
Restrict ball assembly	30-35	300-350	22-25
Reverse shift lever assembly attaching bolt	15-22	150-220	11-15
Bearing retainer bolt	15-22	150-220	11-15
Differential drive gear bolt	130-140	1300-1400	94-101
Interlock plate bolt	20-27	200-270	15-19

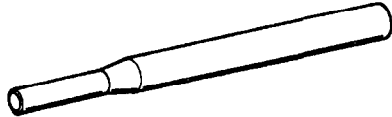
SPECIAL TOOLS

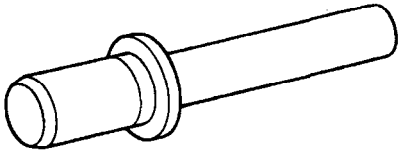
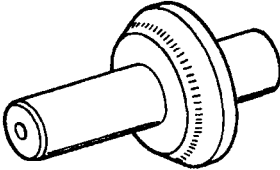
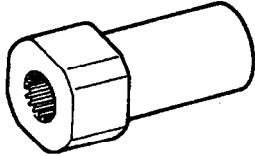
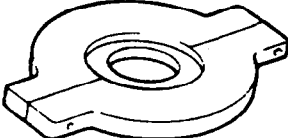
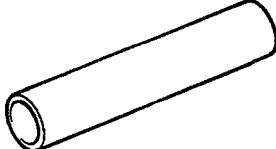
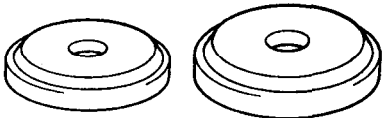
Tool (Number and Name)	Illustration	Use
09414-11000 Lock pin extractor		Driving out the spring pin of the shift fork
09414-11100 Lock pin installer		Driving in the spring pin on the shift fork
09431-21000 Front oil seal installer		Installation of the input shaft front oil seal
09431-21200 Oil seal installer		Installation of differential oil seal
09432-21101 Input shaft holder		Holding the input shaft when loosening input shaft nut
09432-21400 Taper bearing puller		Removal of input shaft front bearing
09432-22000 Bearing installer		Installation of output shaft's gear and sleeve
09432-22100 Bearing outer race installer		Installation of input and output shaft bearing outer race (Use with 09500-11000)

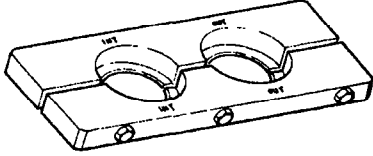
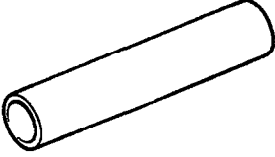
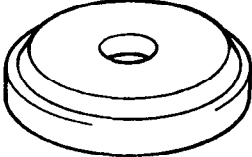
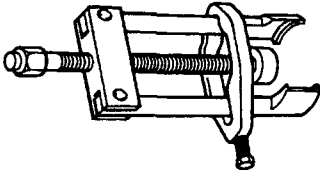
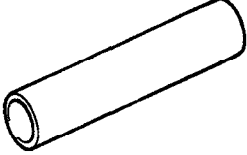
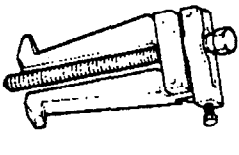
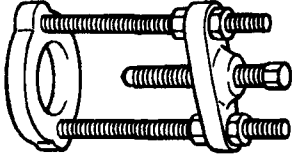
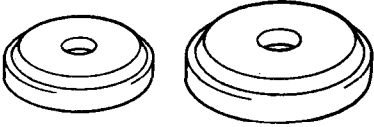
Tool (Number and Name)	Illustration	Use
09432-33200 Bearing removing plate		Removal of input shaft's gear and bearing sleeve
09432-33300 Bearing installer		Installation of input shaft bearing
09432-33400 Bearing race installer		Installation of input shaft bearing outer race (Use with 09500-21000)
09495-33000 Bearing and gear puller		Removal of ball bearing and gear
09455-21100 Bearing installer		1) Installation of gear sleeve and bearing 2) Installation of differential bearing
09455-32200 Oil seal puller		Removal of output shaft bearing outer race
09532-11000 Differential bearing installer		Removal of differential bearing (Use with 09532-11100, 09532-11301)
09532-11500 Pinion bearing outer race installer		Installation of output shaft and differential shaft bearing outer race (Use with 09500-11000)

TROUBLESHOOTING

Symptom	Probable cause	Remedy
Vibration, noise	Loose or damaged transaxle and engine mounts	Tighten or replace mounts
	Inadequate shaft end play	Correct end play
	Worn or damaged gears	Replace gears
	Worn or damaged bearings	Replace bearings
	Use of inferior grade of gear oil	Replace with specified gear oil
	Low oil level	Replenish
	Inadequate engine idle speed	Adjust idle speed
Oil leakage	Broken or damaged oil seal or O-ring	Replace oil seal or O-ring
Hard shift	Faulty control cable	Replace control cable
	Poor contact or wear of synchronizer ring and gear cone	Correct or replace
	Weakened synchronizer spring	Replace synchronizer spring
	Use of inferior grade of gear oil	Replace with specified gear oil
Jumps out of gear	Worn gear shift fork or broken poppet spring	Replace shift fork or poppet spring
	Excessive clearance of synchronizer hub to sleeve spline	Replace synchronizer hub and sleeve
	Worn or damaged gears and/or bearings	Replace

SERVICE ADJUSTMENT PROCEDURES

Oil Level Inspection

1. Remove oil filler plug and check level with finger.
2. Oil level must be up to fill hole. If it is below hole, add oil until it runs out, then reinstall plug.
3. Replace the oil that the transaxle gear oil is noticeably dirty, and that it is not of a suitable viscosity.

OIL CHANGE

Use HP Gear Oil SAE 75W/85W (API-GL 4)

1. With the vehicle parked on a level surface, remove the drain plug and drain the transaxle oil.
2. Reinstall drain plug with new gasket, and transaxle oil total capacity.
2.15 liters (2.27 u.s.qts., 1.89 Imp.qts.)

DRIVE SHAFT OIL SEAL REPLACEMENT

N/A Vehicle

1. Disconnect the drive shaft from the transaxle
(Refer to 49 GROUP)
2. Using a flat-tip screwdriver, remove the oil seal.
3. Using the special too (09431-21200), tap the drive shaft oil seal into the transaxle.
4. Apply a coating of gear oil to the lip of the oil seal.

Transaxle gear oil: Hypoid gear oil, SAE 75W/85W conforming to API GL-4 or higher.

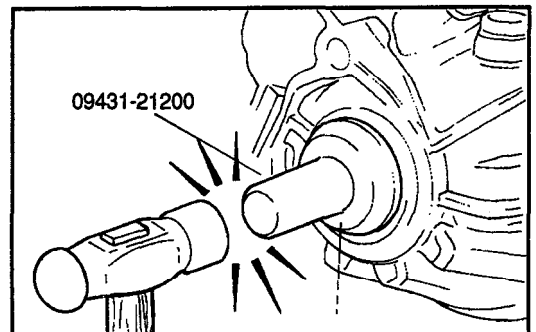
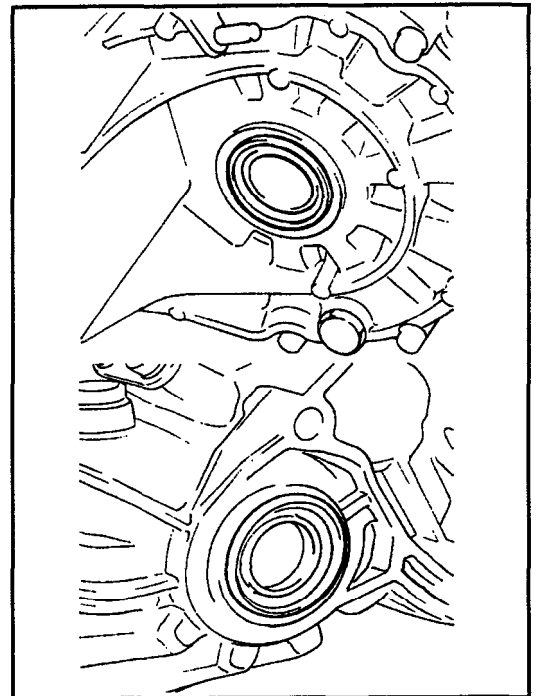

T/C VEHICLE

1. Disconnect the drive shaft from the transaxle.
(Refer to 49 GROUP)
2. Remove the intermediate shaft by removing the 2 bolts.

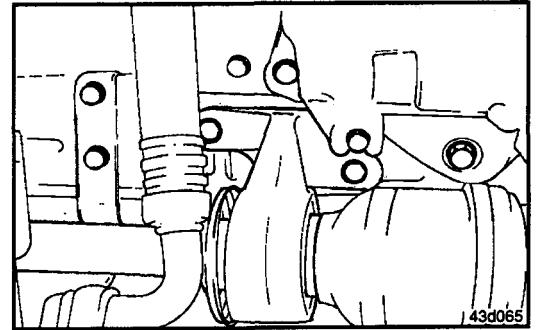

3. Using a flat-tip screwdriver, remove the oil seal.

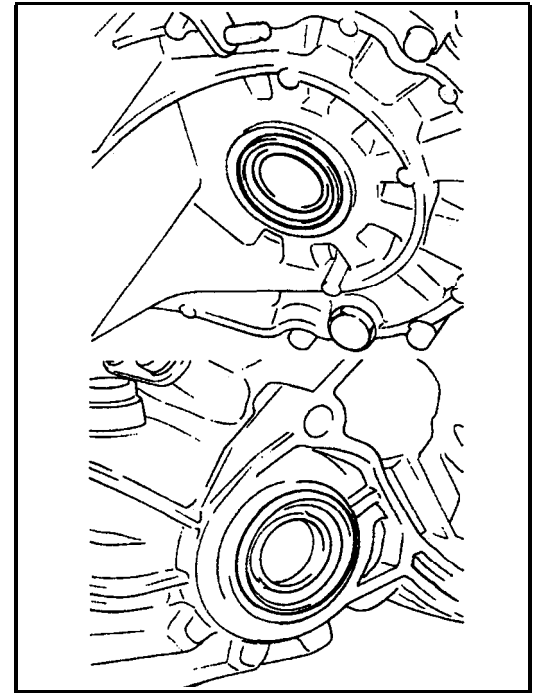

4. Using the special too (09431-21200), tap the drive shaft oil seal into the transaxle.
5. Apply a coating of gear oil to the lip of the oil seal.

Transaxle gear oil: Hypoid gear oil, SAE 75W/85W conforming to API GL-4 or higher.

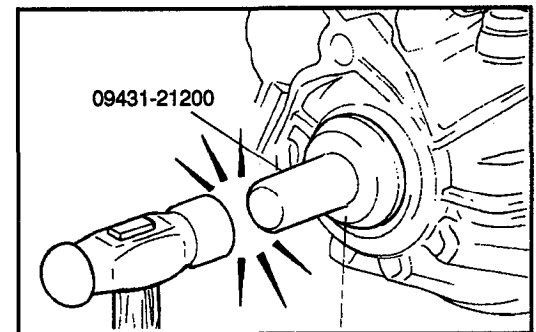

SPEEDOMETER CABLE REPLACEMENT

1. Correctly insert the adapter into the instrument panel, and fasten the new speedometer cable.

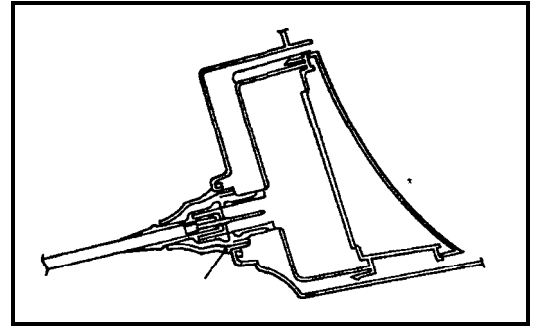

2. Install the grommet so the cable attachment part and the projecting part are horizontal, as shown in the illustration.

Caution

The cable should be installed so that the radius of the cable bend is 150 mm (5.9 in.) or more.

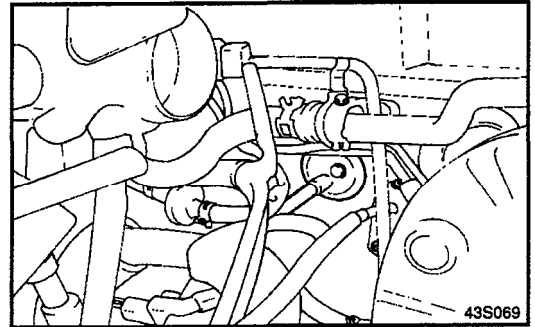

3. At the transaxle, the cable should be inserted into the transaxle, and the nut should be securely tightened.

Caution:

If the cable is not correctly and securely connected, it may cause the speedometer to read incorrectly or it may produce abnormal noise.

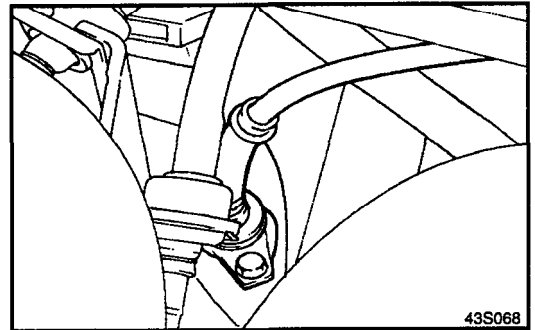

MANUAL TRANSAXLE CONTROL

COMPONENTS

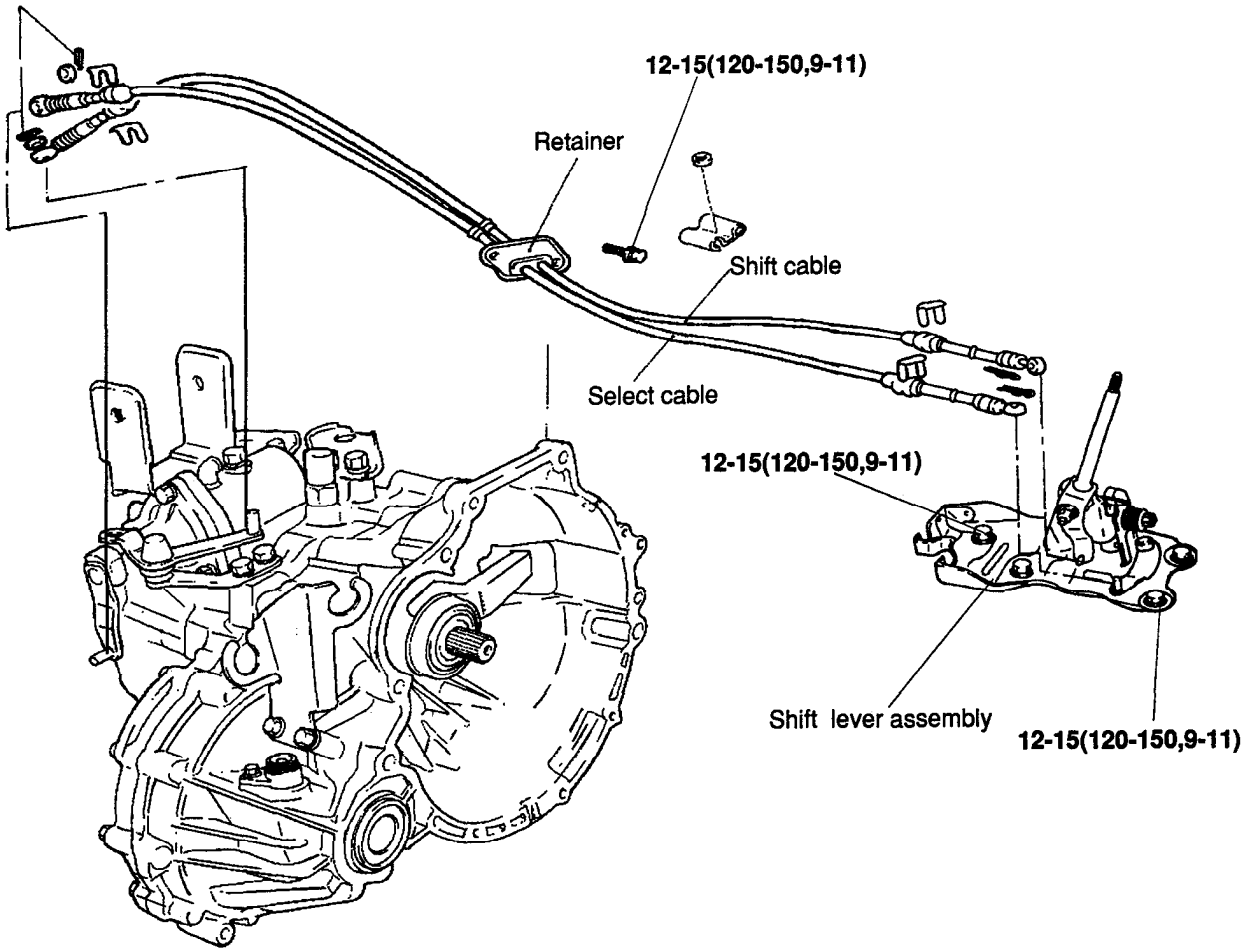

TORQUE : Nm (kg.cm, lb.ft)

REMOVAL

1. Remove the console assembly (Refer to CONSOLE).
2. Remove the cotter pins and clips (shift lever side).
3. Remove the shift lever assembly.

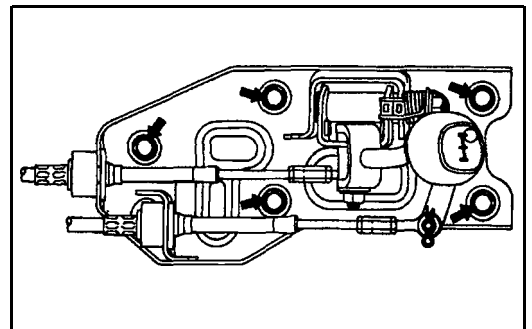

4. Remove the retainer and bolts.
5. Remove the cotter pins and clips (Transaxle side).
6. Remove the shift cable and select cable.

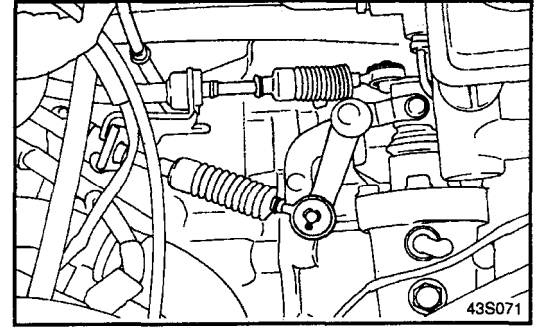

INSPECTION

1. Check the select cable for proper operation and for damage.
2. Check the shift cable for proper operation and for damage.
3. Check the boot for damage.
4. Check each bushing for wear, abrasion, sticking, restricted movement or damage.
5. Check for a weak or damaged spring.

INSTALLATION

1. Install the shift lever assembly.
2. Installation of shift lever and select cable.
 - 1) Move the transaxle select lever and shift lever to the neutral position.
 - 2) When connecting the select cable to lever (B), adjust the select cable's length so that lever (B) is at the neutral position.
 - 3) The flange side of the resin bushing at the select cable end should be at the lever (B) end surface.
 - 4) The flange side of the resin bushing at the shift cable end should be at the shift lever's cotter pin hole.
 - 5) After connecting the shift cable, check that the dimensions (A) and (B) shown in the illustration are equal.
 - 6) Move the shift lever to each position and verify that the shifting is smooth.
3. Install the retainer and bolts

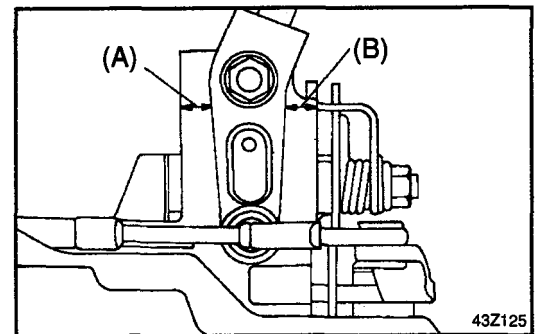
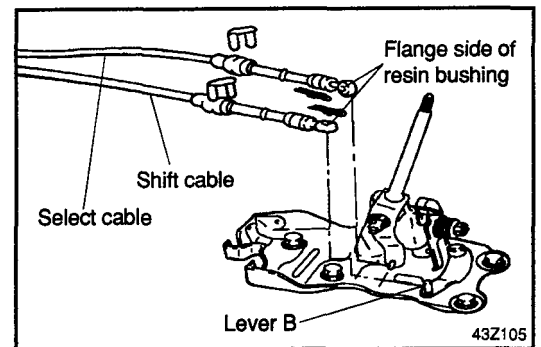

SHIFT LEVER ASSEMBLY

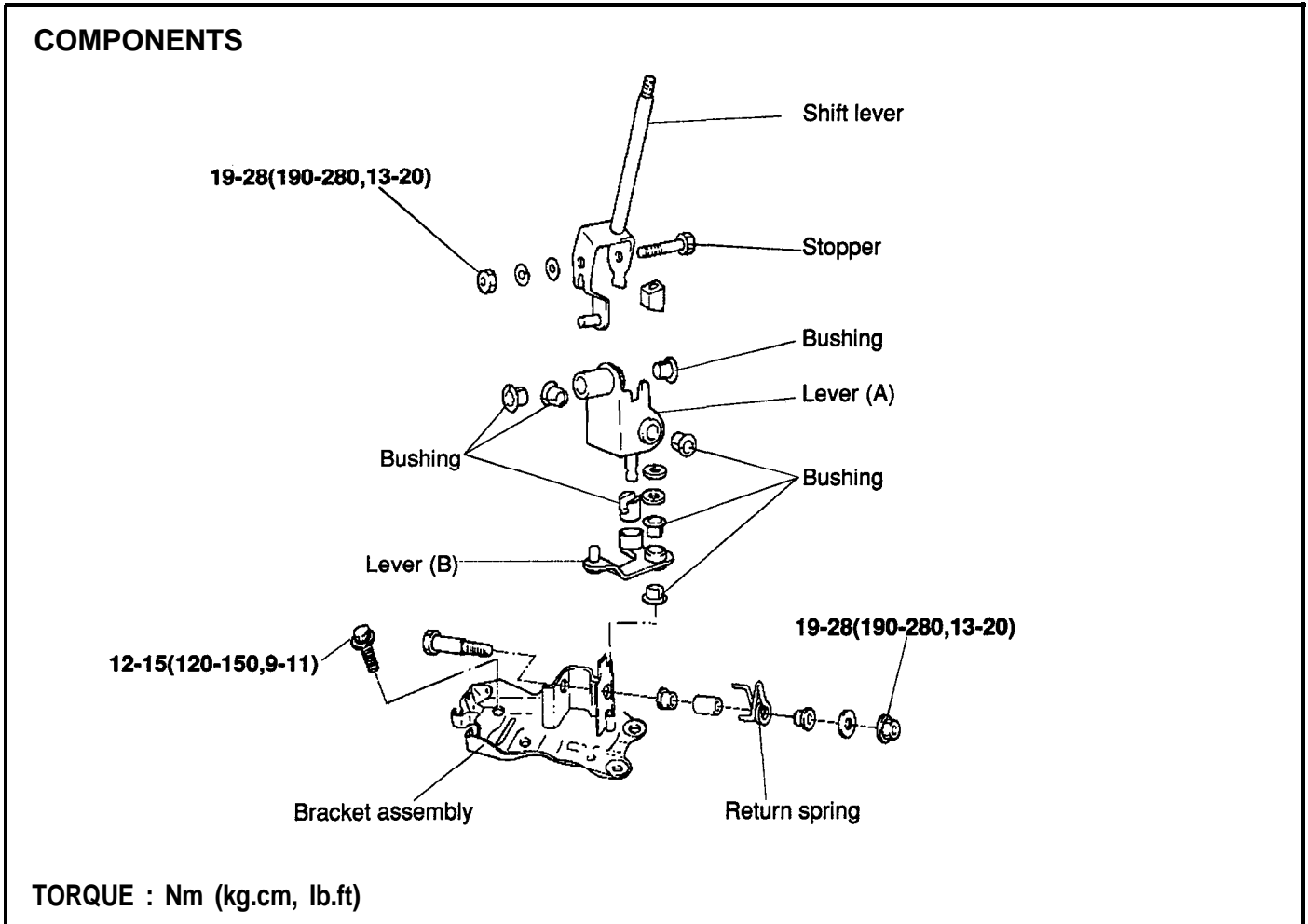

INSPECTION

1. Check the bushing for wear or damage.
2. Check the return spring for damage or deterioration.

ASSEMBLY

1. Apply multi-purpose grease to the sliding part of the bushings.
2. Assembly is reverse of the disassembly.

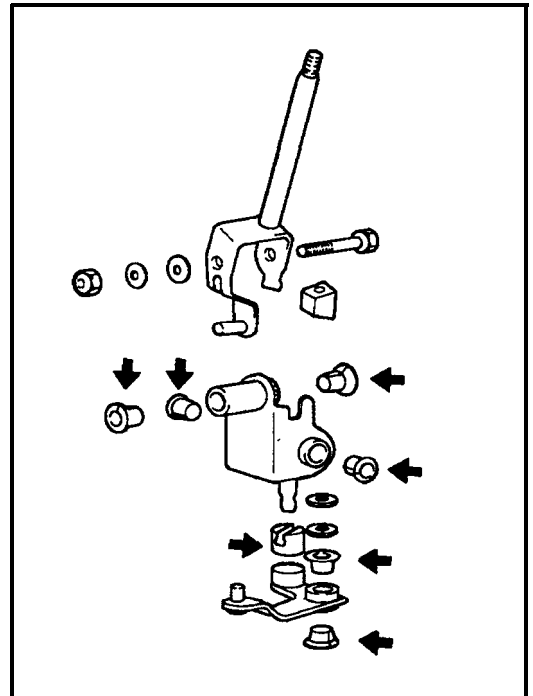

MANUAL TRANSAXLE

COMPONENTS

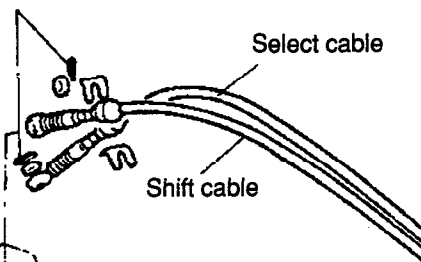
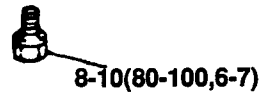
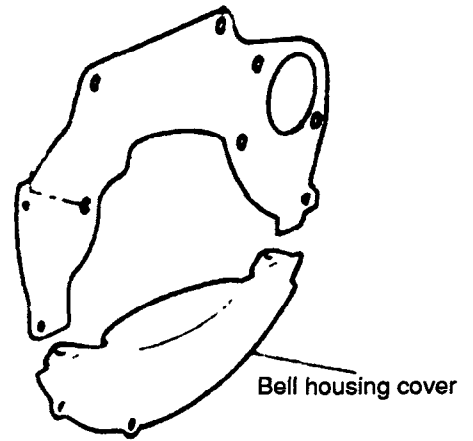
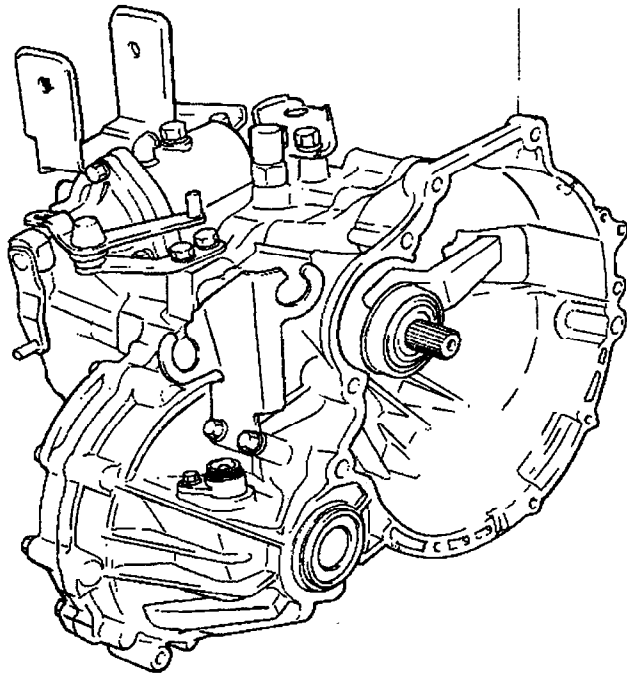

27-34(270-340,20-25)

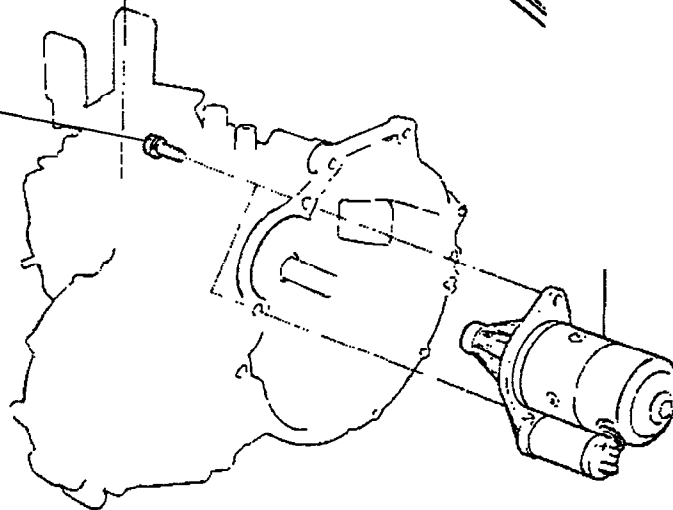

TORQUE : Nm (kg.cm, lb.ft)

REMOVAL

1. Remove the drain plug and drain the transaxle gear oil.
2. Remove the clutch release cylinder (Refer to the CLUTCH SECTION)
3. Remove the air cleaner assembly.
4. Remove the select cable and shift cable (Refer to MANUAL TRANSAXLE CONTROL SECTION)

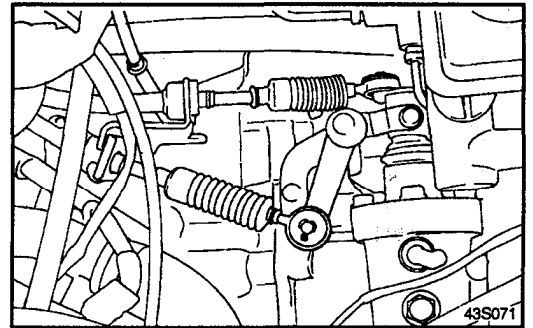

5. Disconnect the backup light switch connector.
6. Remove the speedometer cable.
7. Disconnect the clutch cable or clutch tube.

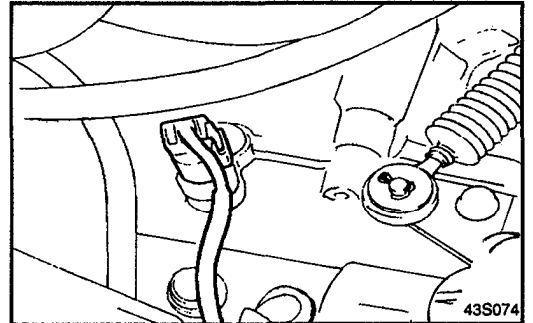

8. Remove the starter motor mounting bolts. Remove the transaxle assembly upper connecting bolts and transaxle mounting bracket bolt.

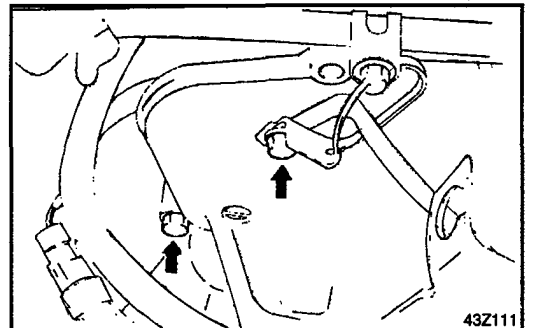

9. Remove the splash shield.
10. Remove the intermediate shaft by removing 2 bolts. (T/C only)
11. Disconnect the tie rod end, lower the arm ball joint and drive shaft (Refer to DRIVE SHAFT AND FRONT AXLE SECTION)

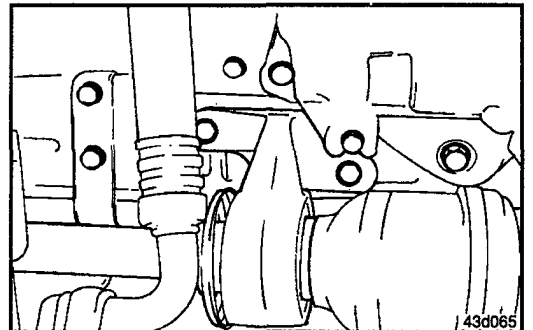

12. Remove the bell housing cover.

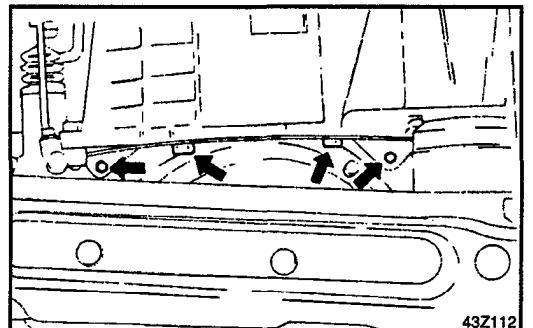

13. Remove the transaxle assembly lower mounting bolts with the transaxle assembly supported by a jack.
14. Remove the transaxle assembly.

NOTE

When supporting the transaxle assembly make sure that the lifting force is applied to a wide area, not to a small localized area.

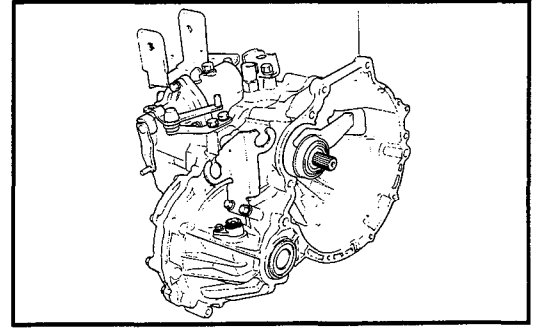
**INSTALLATION**

1. Installation is the reverse of removal.

MANUAL TRANSAXLE ASSEMBLY

COMPONENTS

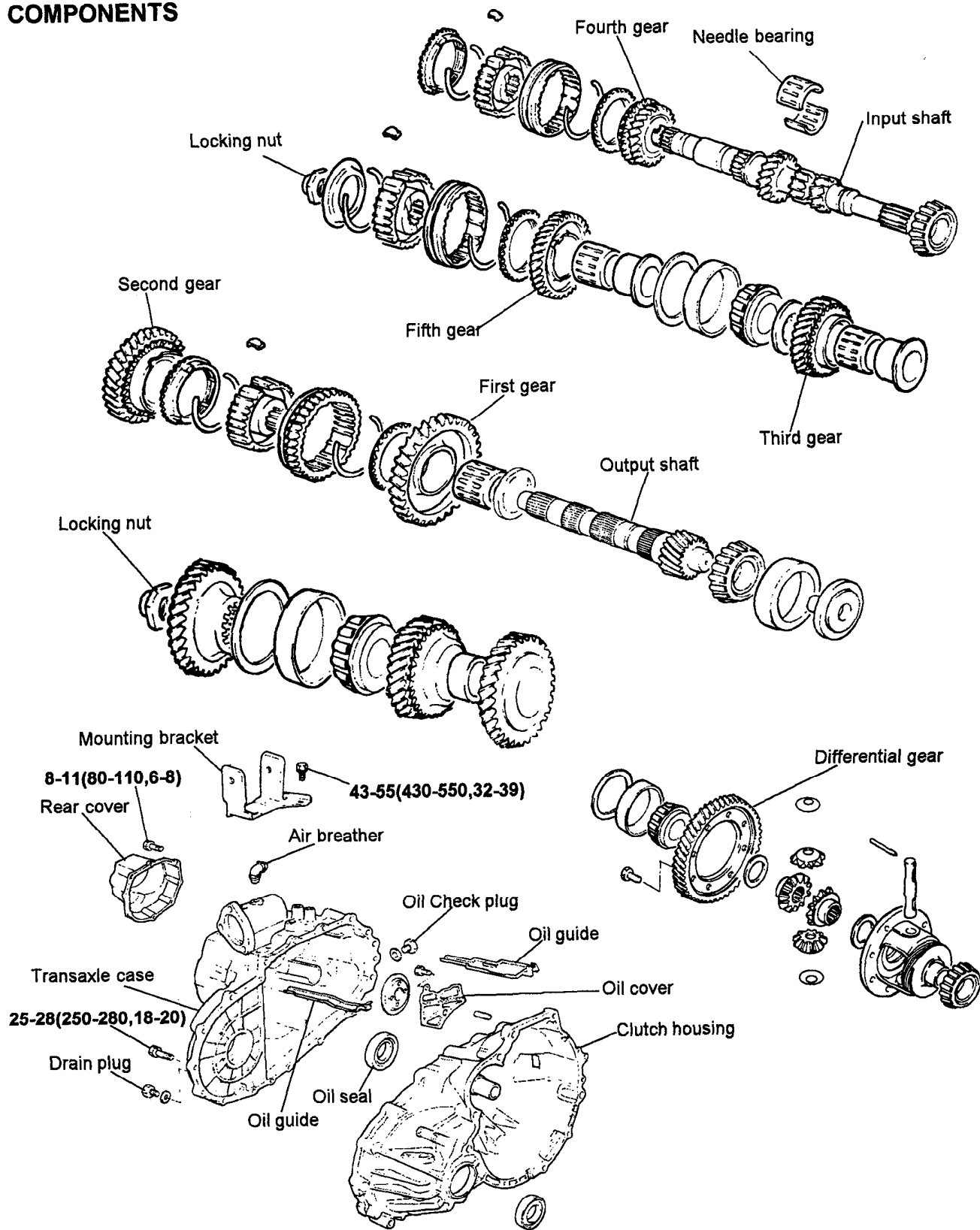

DISASSEMBLY

1. Remove the back up light switch, gasket, mounting bracket, restrict ball assembly and mounting bracket.

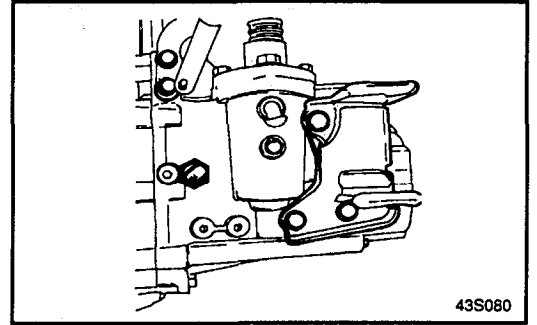

2. Remove the rear cover bolt and rear cover.

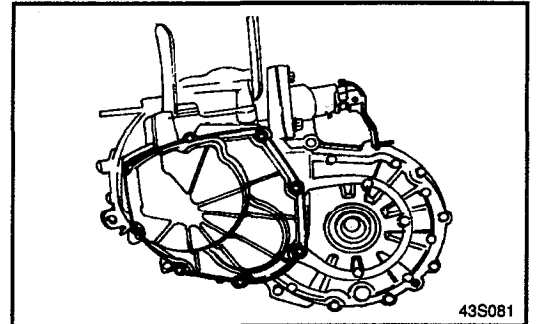

3. Remove the seal bolts, spring cases, poppet springs and poppet balls.

NOTE

Be careful not to lose the springs or balls.

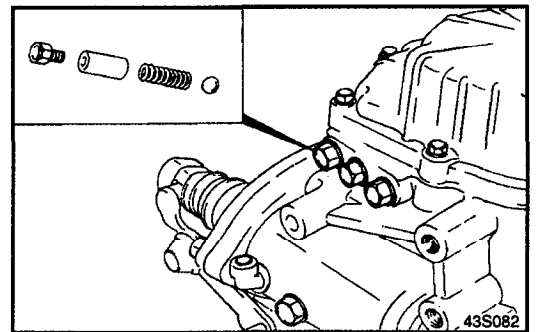

4. Remove the fifth speed shift fork spring pin using the special tool (09414-11000)

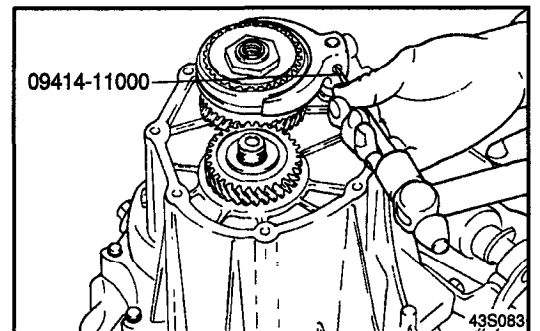

5. To remove the lock nuts of input shaft and output shaft, unstake the lock nuts.

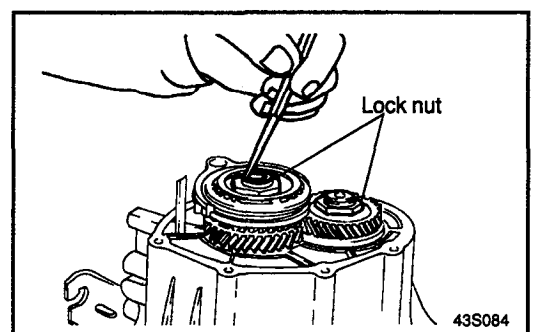

6. Shift the transaxle into First speed using the control lever and select lever.

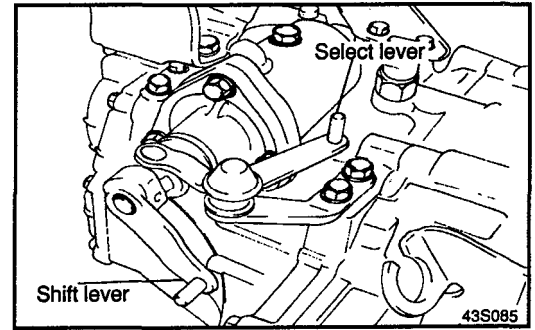

7. Shift the fifth speed synchronizer to fifth speed gear, then loosen and remove the lock nuts.

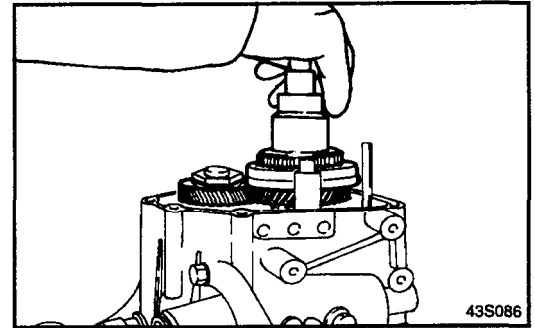

8. Remove the fifth speed synchronizer sleeve and shift fork.
9. Remove the fifth synchronizer hub and ring with fifth speed gear and needle bearing using the special tool (09495-33000)
10. Remove the fifth speed gear on the output shaft using the special tool (09495-33000)

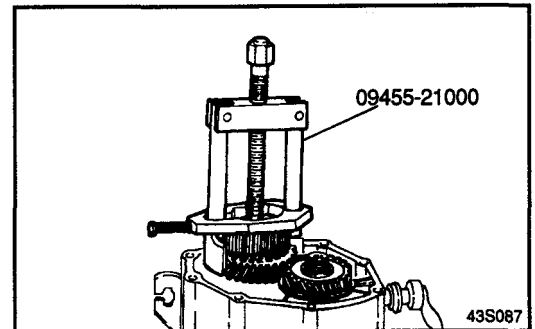

11. Remove the select lever assembly and select lever shoe.

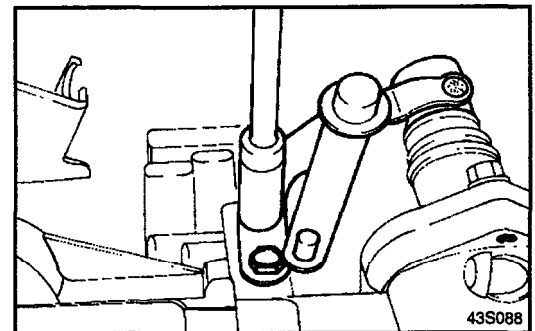

12. Remove the control shaft mounting bolts on the neutral position.
13. Remove the interlock plate fixed bolt and air breather.
14. Remove the control shaft assembly.

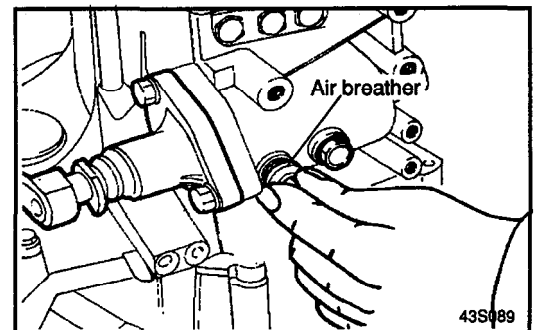

15. Remove the reverse gear shaft bolt.

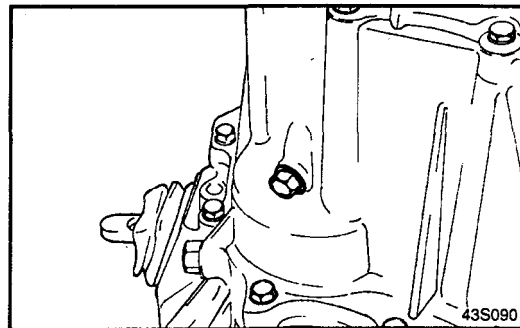

16. Remove the transaxle case fixing bolts in the clutch housing.

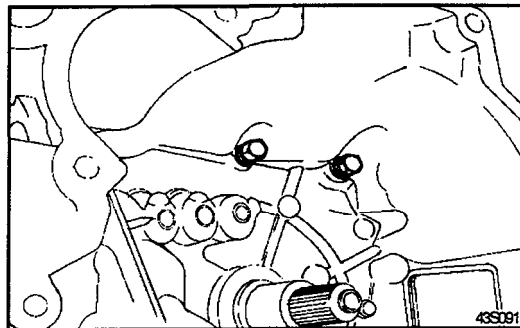

17. Remove the bolts attaching transaxle case and detach it.

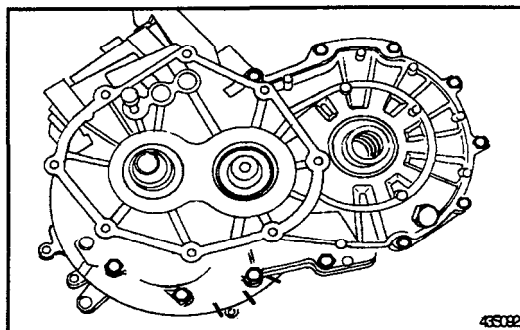

18. Remove the oil guides.

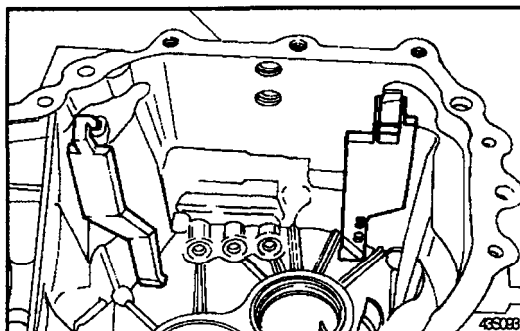

19. Remove the drive shaft bearing outer racer and spacer using special tool (09455-32200).

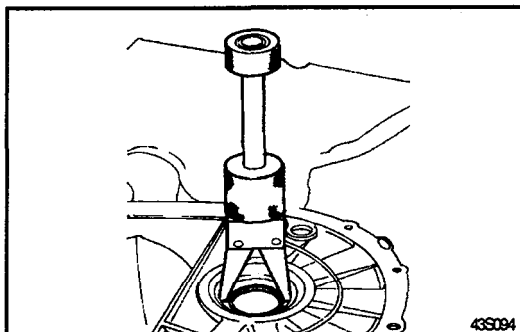

- 20. Remove the output shaft bearing outer race and spacer using the special tool (09455-32200).
- 21. Remove the input shaft bearing outer race and spacer.

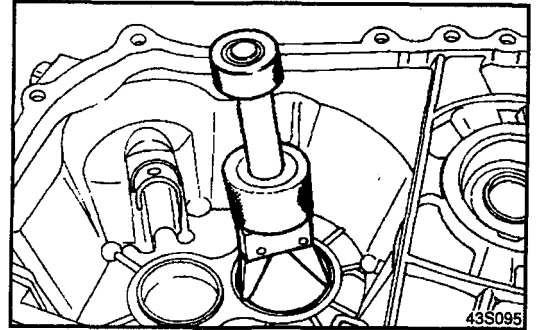

- 22. Remove the bolts on the reverse shift lever and the reverse shift lever assembly and reverse shift lever shoe.

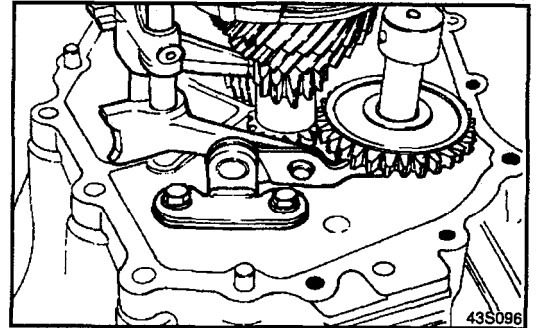

- 23. Remove the reverse idler gear and the reverse idler gear shaft.

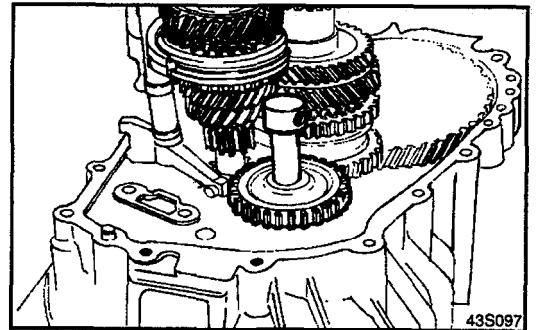

- 24. Remove the spring pins of the shift fork using the special tool (09414-11000).

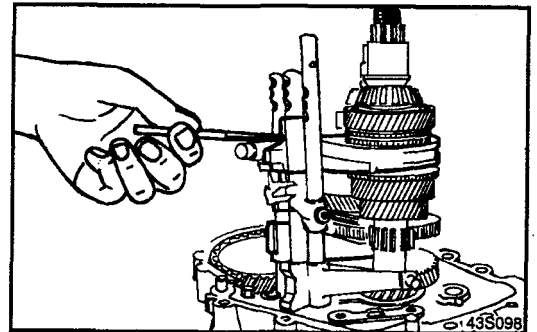

- 25. Detach the shift rail and fork assembly.

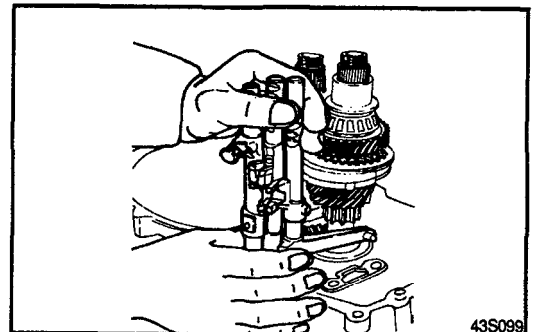

26. Remove the input shaft assembly and output shaft assembly at the same time.

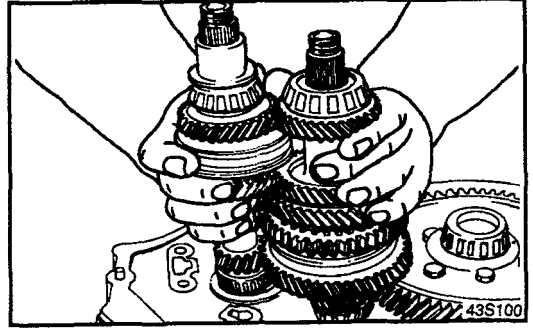

27. Remove the differential gear assembly.

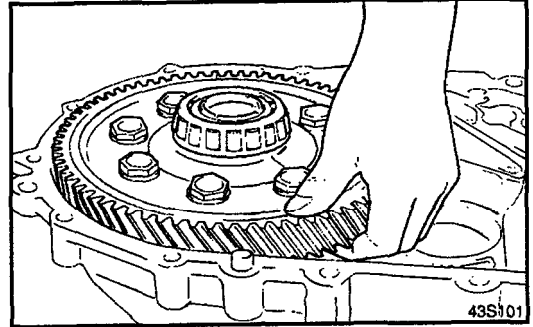

28. Remove the speedometer driven gear assembly and cable support bracket assembly.

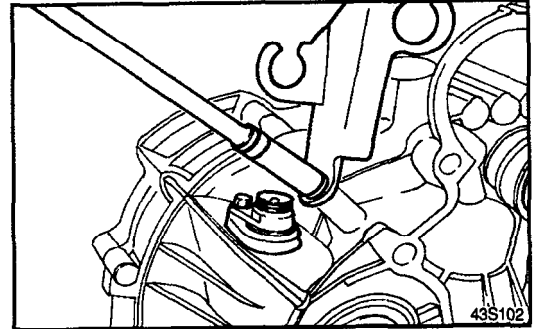

29. Remove the input shaft bearing outer race using (09455-32200) the special tool.

30. Remove the output shaft bearing outer race.

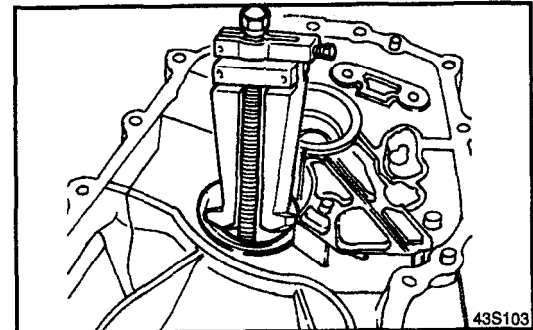

31. Remove the drive shaft bearing outer race using the special tool (09455-32200).

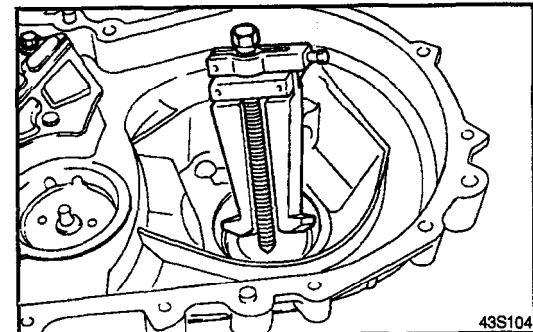

32. Remove the oil cover.

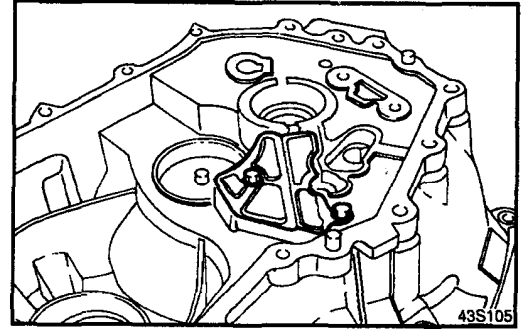

33. Remove the differential side oil seal.

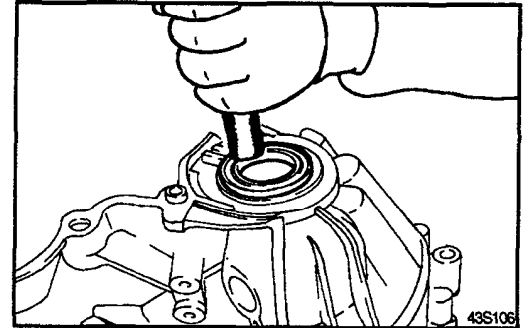

34. Remove the output shaft oil guide.

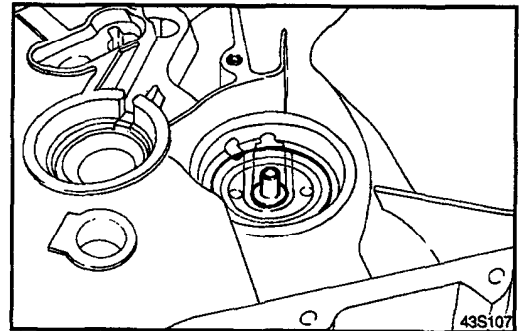

35. Remove the input shaft oil seal.

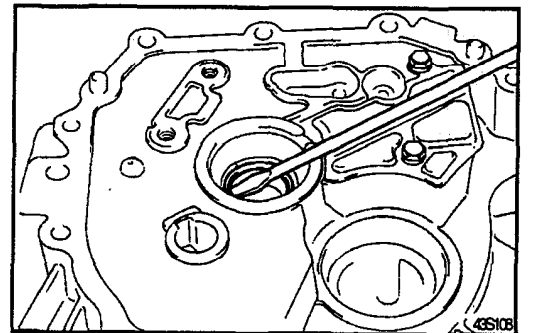

REASSEMBLY

Assembly procedure is the reverse of removal procedure.

1. Install the drive shaft oil seal using the special tool (09431-21000).

NOTE

Insert the oil seal straightly.

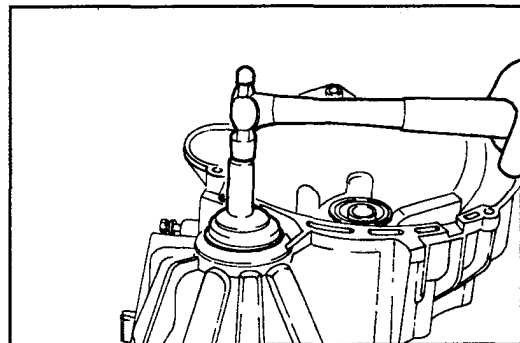

2. Install the input shaft front oil seal using the special tool (09431-21000).

Caution

Do not reuse the oil seal.

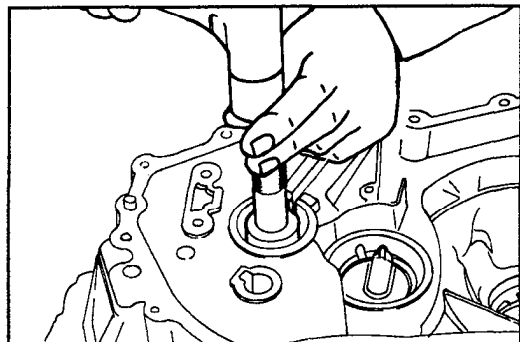

3. Install the output shaft oil guide in the direction illustrated.

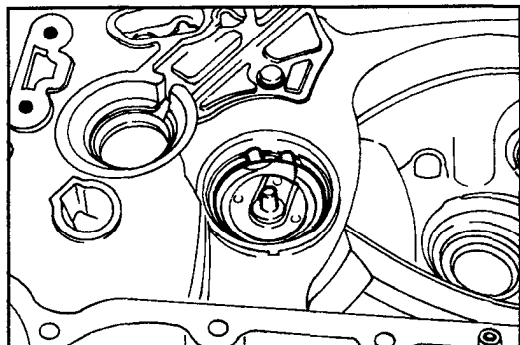

4. Install the input shaft bearing outer race using the special tool (09455-21100).
5. Install the output shaft bearing outer race using the special tool (09532-11500).

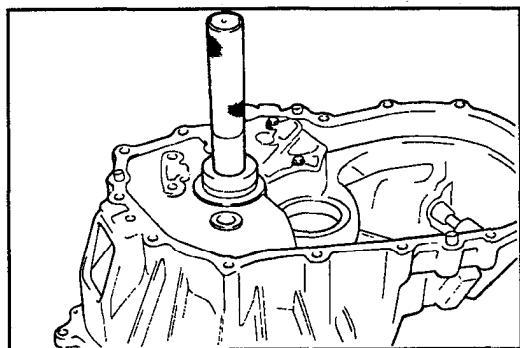

6. Install the drive shaft bearing outer race using the special tool (09532-11500).

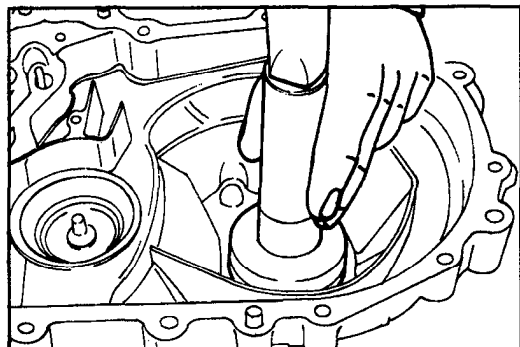

7. Install the oil cover.
8. Install the differential gear assembly.
9. Install the input shaft assembly and the output shaft assembly at the same time.

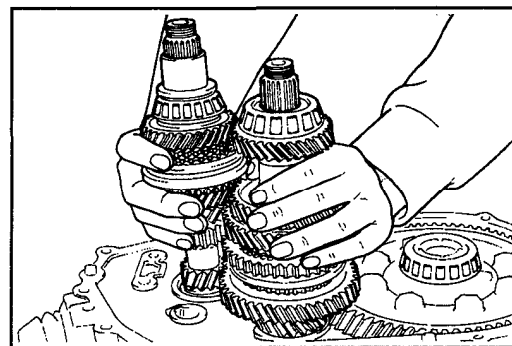

10. Reassembly the shift rail assemblies.
 - 1) Place the first and second speed synchronizer sleeve to neutral position.
 - 2) Place the third and fourth speed synchronizer sleeve to neutral position..
 - 3) Install the shift rail and fork assemblies.

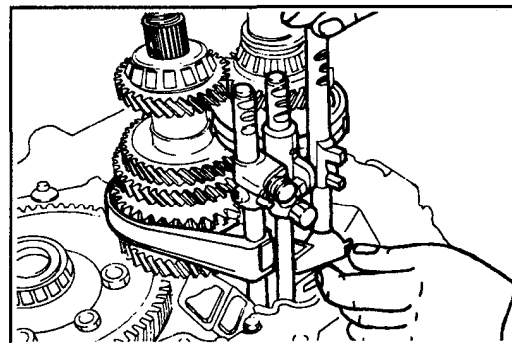

11. Reassembly of spring pin.
 - 1) Install the spring pins using the special tool (09414-11100) or pin punch.

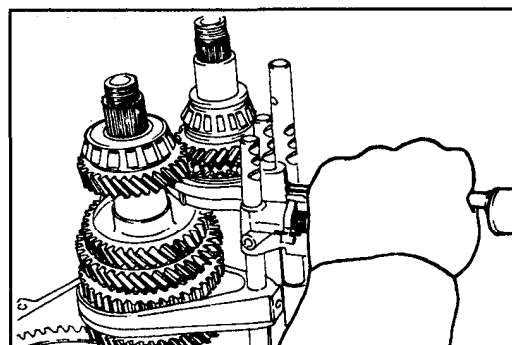

- 2) When installing, make sure that the slit of the spring pin is aligned with center line of the shift rail.

CAUTION

Do not reuse the spring pin.

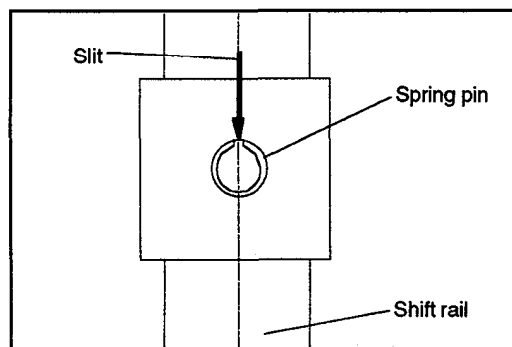

12. Install the reverse idler gear and reverse idler gear shaft in the direction illustrated.

13. Install the reverse shift lever assembly and shoe.

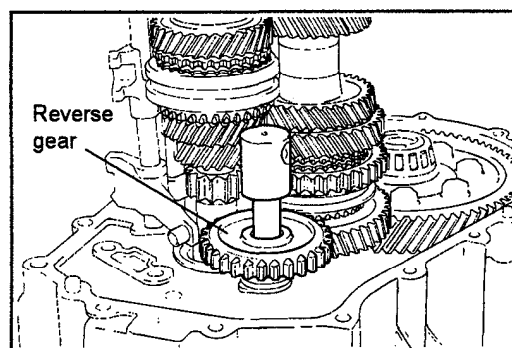

14. Install the drive shaft oil seal in the transaxle case using the special tool (09431-21200).

Caution

Do not reuse the oil seal.

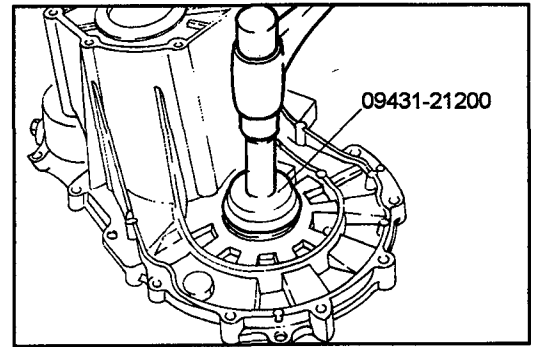

15. Install the input shaft roller bearing outer race and spacer using the special tools (09432-33400, 09500-11000).

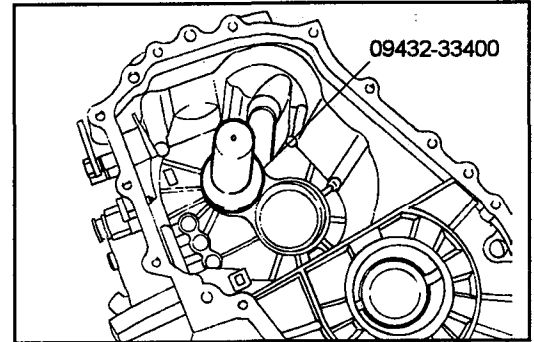

16. Install the output shaft bearing outer race and spacer using the special tools (09500-11000, 09432-22100A).
17. Install the drive shaft bearing outer race and spacer using the special tools (09500-11000, 09532-11500).

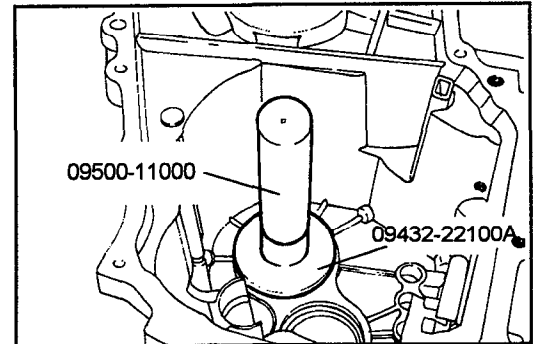

18. Installation of spacer.
- 1) Place two pieces of rosin-coresholder with 3 mm in diameter on the bearing outer race as illustrated.
 - 2) Install the transaxle case temporarily and tighten the bolts to the specified torque, then remove the transaxle case.
 - 3) Detach the crushed solders.
 - 4) Measure the thickness of the crushed solder. Select and install the proper spacers which complete following specification.

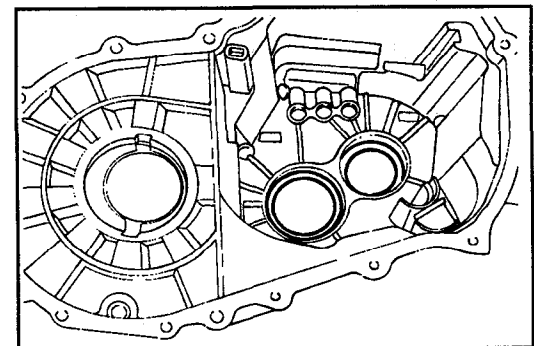

Standard value (End play)

Input shaft end 0-0.05 mm

Output shaft 0.15-9.20 mm

Differential case 0.25-0.30 mm

For proper spacer, refer to relevant parts catalog.

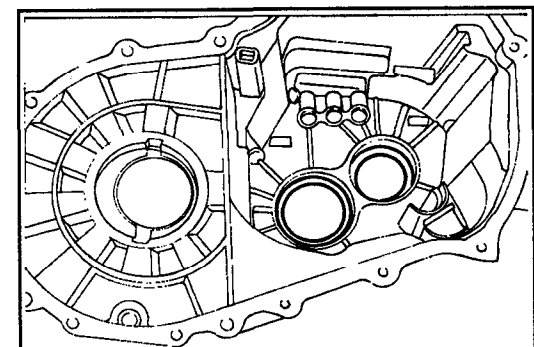

19. Install the oil guide in the transaxle case.

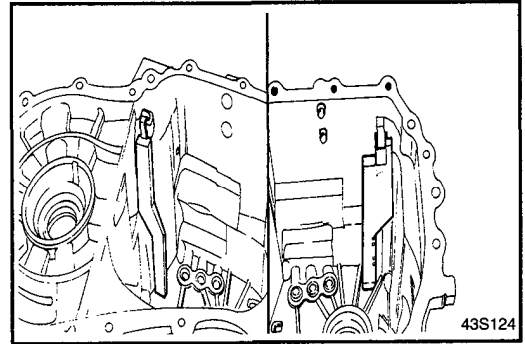

20. Apply the specified sealant to the clutch housing side of the transaxle case.

Specified sealant : THREE BOND 1216

21. Install the transaxle case onto the clutch housing assembly and tighten the bolts.

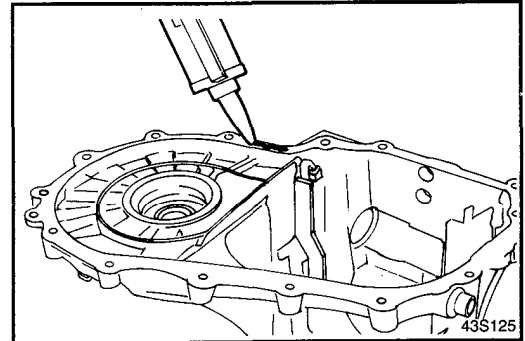

22. Center the shaft with screw driver.
 23. Tighten the reverse gear shaft bolt to the specified torque.

Tightening torque	
Reverse gear shaft bolt	43-55 Nm (430-550 kg.cm, 32-39 lb.ft)

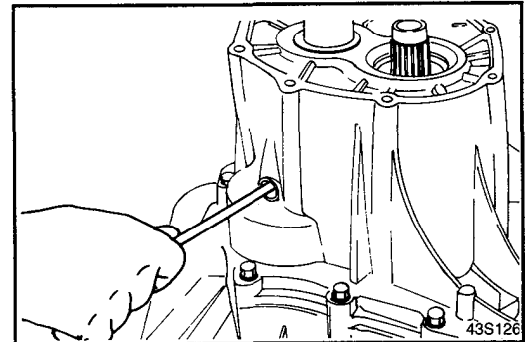

24. Install poppet balls, poppet springs, spring cases and seal bolts.

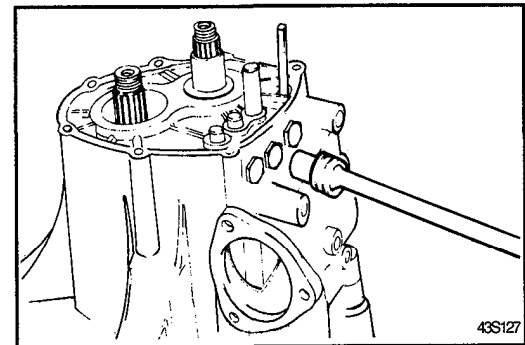

25. Install the control shaft assembly on the neutral condition and tighten the mounting bolts.
 26. Install the interlock plate fixed bolt and washer and air breather.
 27. Apply sealant to the air breather and attach it.

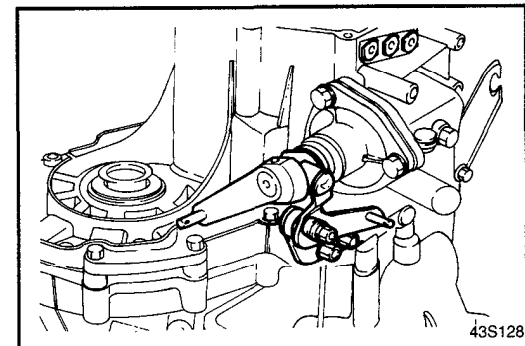

28. Install the fifth speed output gear to the output shaft using the special tool (09432-33300)

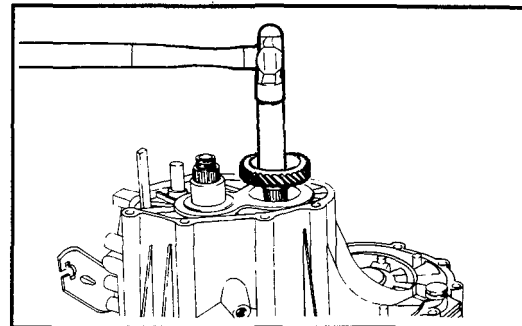

29. Install the 5th speed sleeve, needle roller bearing, fifth speed gear with synchronizer ring.
 30. Install the fifth speed synchronizer hub.

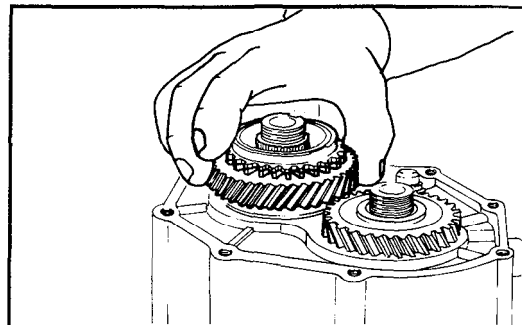

31. Install the fifth speed gear shift fork and the synchronizer sleeve at the same time.

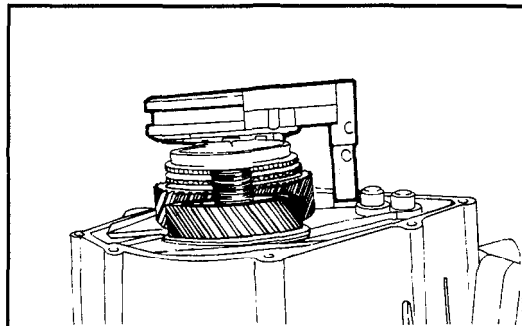

32. Installation of locking nut.

- 1) Shift the transaxle into first speed with the control lever and select lever.
- 2) Engage the fifth speed sleeve to the fifth speed gear.
- 3) Tighten the lock nut to the specified torque.
- 4) Stake the locking nut.

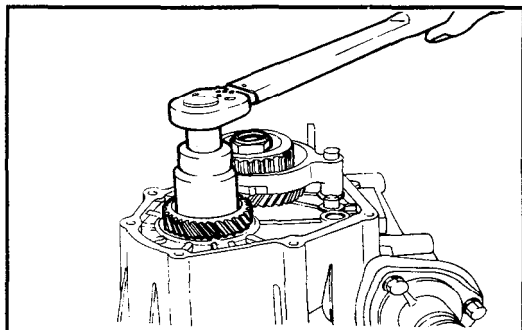

33. Install the spring pin using the special tool (09414-11100) or pin punch.

NOTE

The slit of spring pin should be aligned with center line of the shift rail.

Caution

Do not reuse the spring pin.

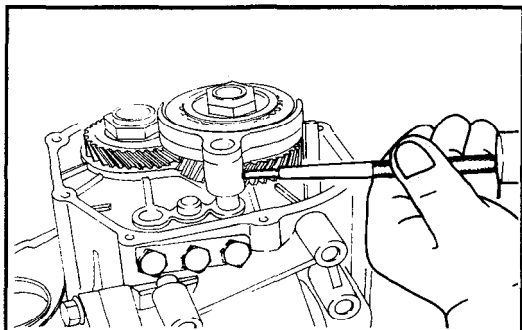

34. Apply the specified sealant to the rear cover and install the rear cover.

Specified sealant : THREE BOND 1216

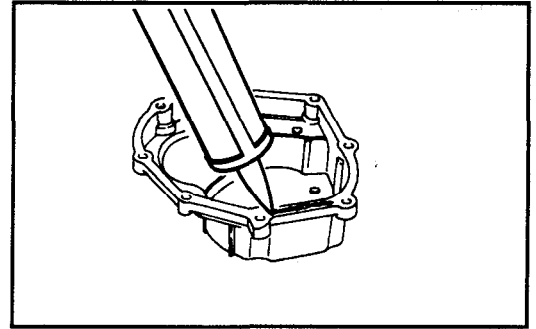

35. Install the speedometer driven gear assembly.
 36. Install the shift control cable support bracket.

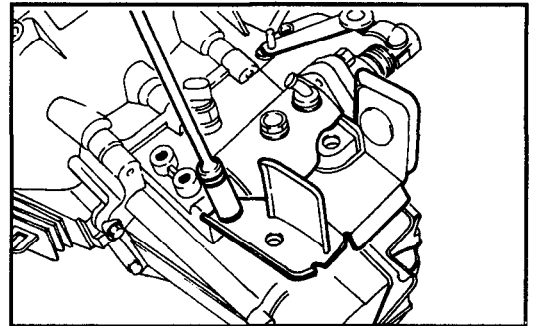

37. Install the back up light switch, gasket, restrict ball assembly.
 38. Install the mounting bracket.

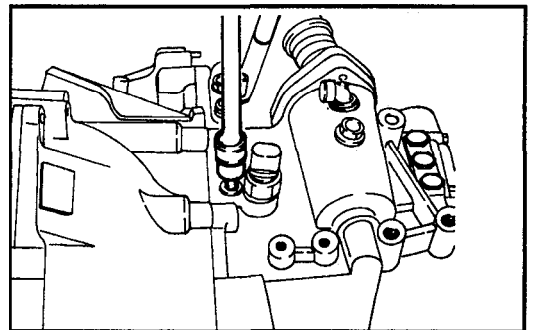

39. Install the select lever assembly.

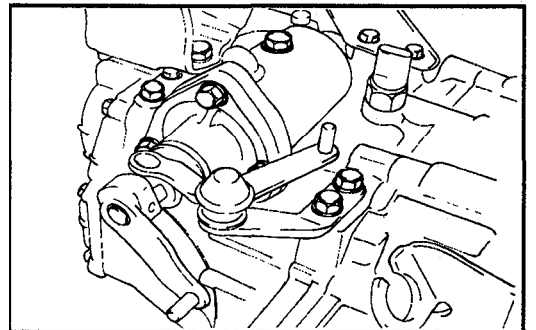

FIFTH SPEED SYNCHRONIZER ASSEMBLY

COMPONENTS

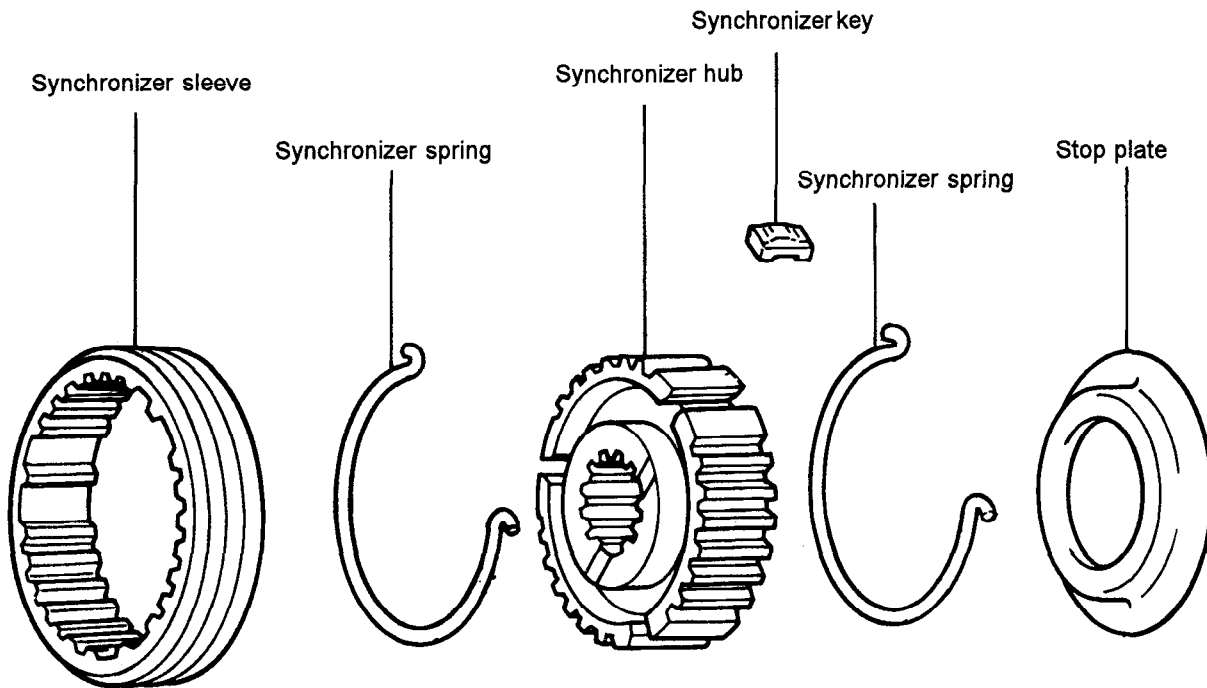

INSPECTION

SYNCHRONIZER SLEEVE AND HUB

1. Install the synchronizer sleeve on the hub and check that they slide smoothly.
2. Check that the sleeve is free from damage.
3. Check for wear of the hub front end (surface in contact with the fifth speed gear).

Caution

Replace the synchronizer hub and sleeve as a set.

SYNCHRONIZER KEY AND SPRING

1. Check for wear of the synchronizer key center protrusion.
2. Check the spring for weakness, deformation and breakage.

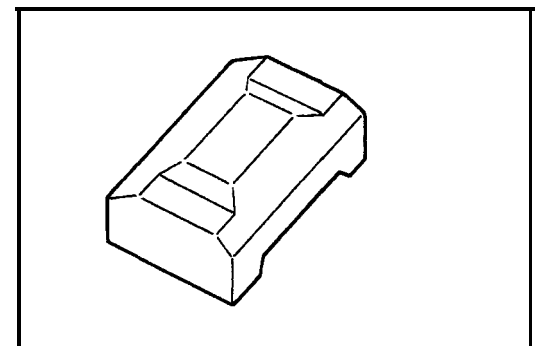
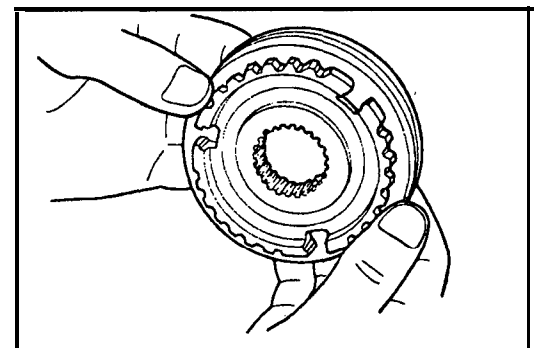

ASSEMBLY

1. Assemble the synchronizer hub, sleeve and key noting their direction.

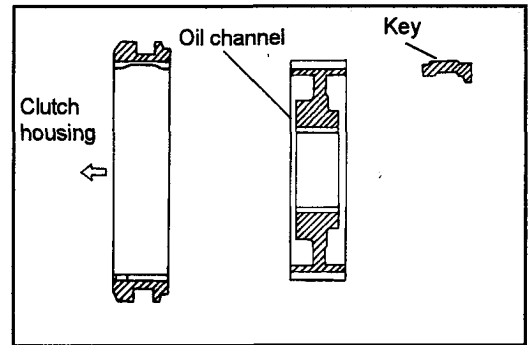

2. The synchronizer sleeve has teeth missing at six portions. Assemble the hub to the sleeve so that the center tooth between the two missing teeth will touch the synchronizer key.

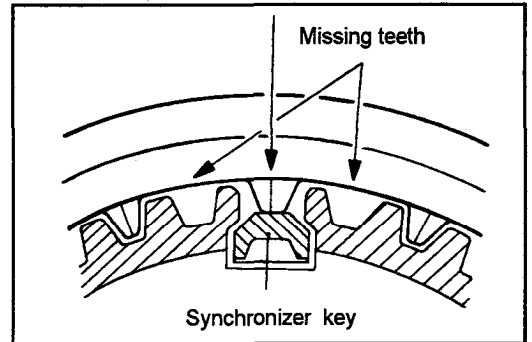

3. Install the synchronizer spring so that its protrusion may be engaged in the groove of the synchronizer key.

Caution

When installing the synchronizer springs, make sure that the front and rear ones are not faced in same direction.

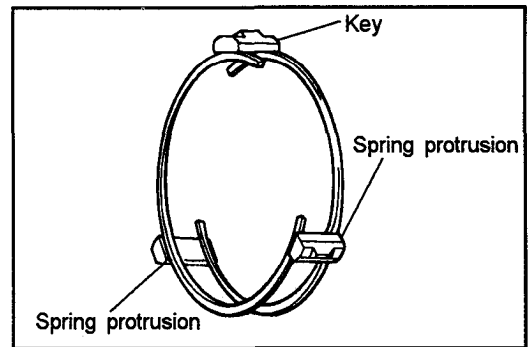

INPUT SHAFT

COMPONENTS

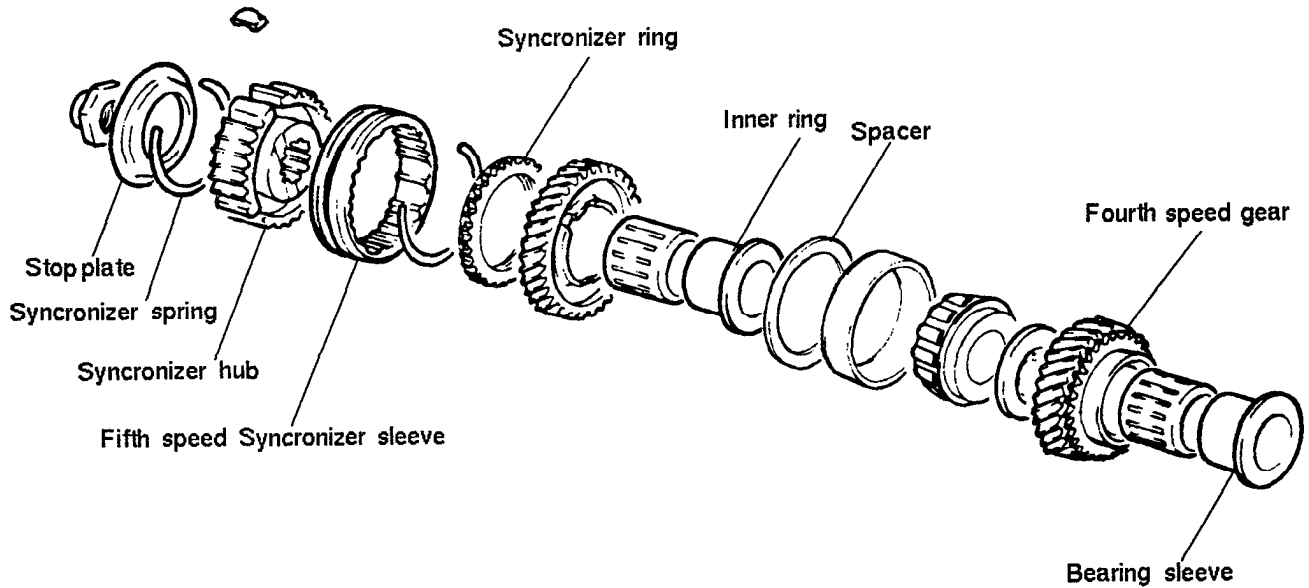
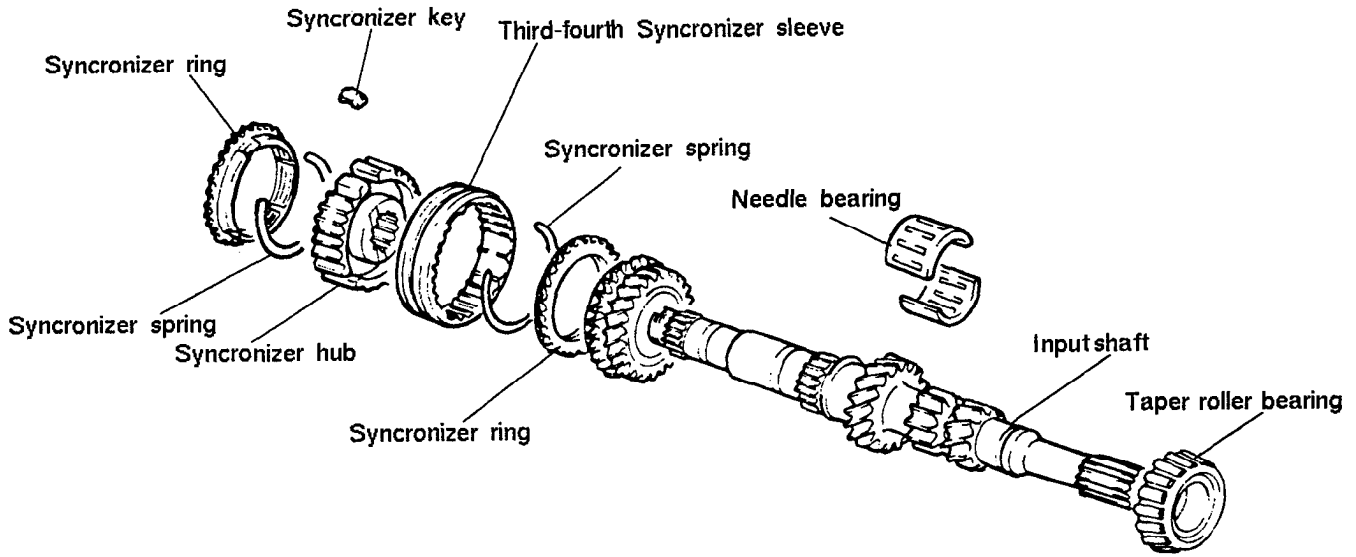

DISASSEMBLY

1. Press and remove the front taper roller bearing using the special tool (09432-21400).
2. Remove the fifth speed gear sleeve, taper roller bearing, fourth speed gear assembly, third-fourth synchronizer hub, sleeve and ring and third speed gear assembly and needle roller bearing using the special tool (094320-33200).

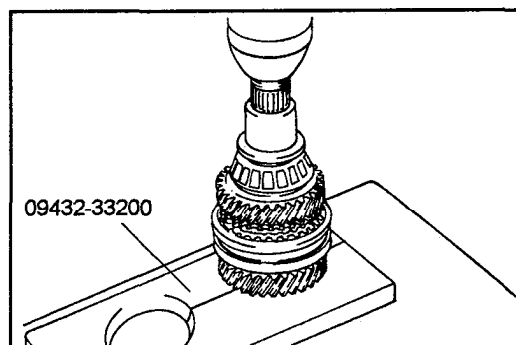
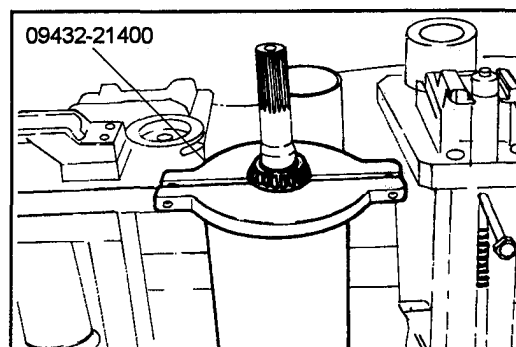

INSPECTION

INPUT SHAFT

1. Check the outer surface of the input shaft where the needle bearing is mounted for damage or abnormal wear [portion (A)].
2. Check the splines for damage or wear.

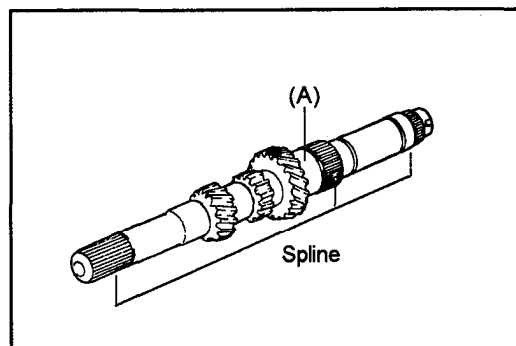

NEEDLE BEARING

1. Install the needle bearing on the shaft with the bearing sleeve and gear. Check that it rotates smoothly without abnormal noise or play.
2. Check the needle bearing cage for distortion.

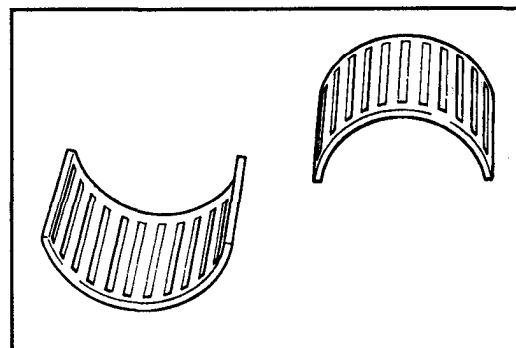

SYNCHRONIZER RING

1. Check the clutch gear teeth for damage.
2. Check the internal surface for damage, wear or broken grooves.

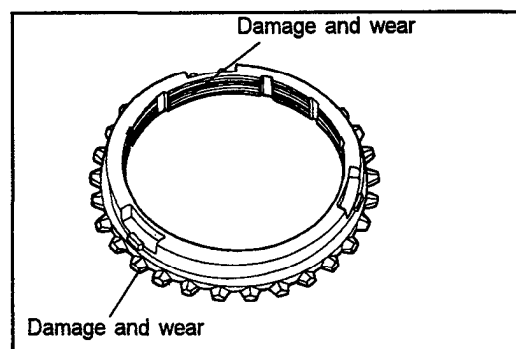

3. Push the synchronizer ring toward the clutch gear and check clearance "A". Replace if it is not within specification.

Limit : 0.5 mm (0.02 in.)

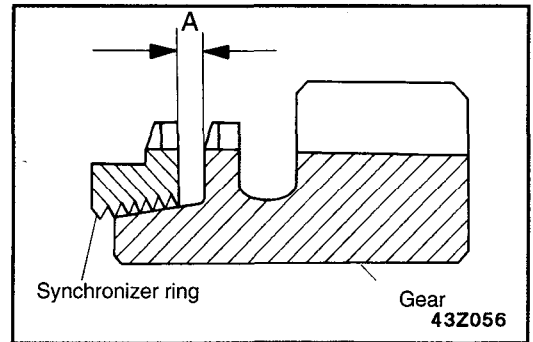

SYNCHRONIZER SLEEVE AND HUB

1. Install the synchronizer sleeve on the hub and check that it slide smoothly.
2. Check that the sleeve is free from damage.
3. Check for wear of the hub end surfaces (in contact with each speed gear).

Caution

Replace the synchronizer hub and sleeve as a set.

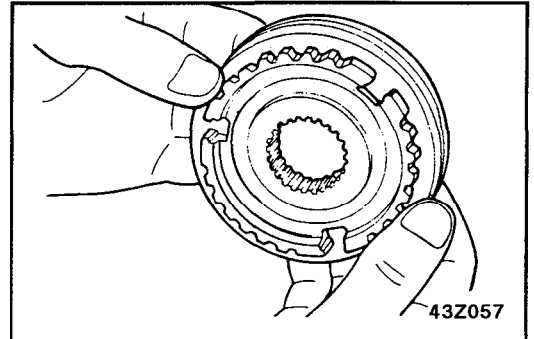

SYNCHRONIZER KEY AND SPRING

1. Check for wear of the synchronizer key center protrusion.
2. Check the spring for weakness, deformation and breakage.

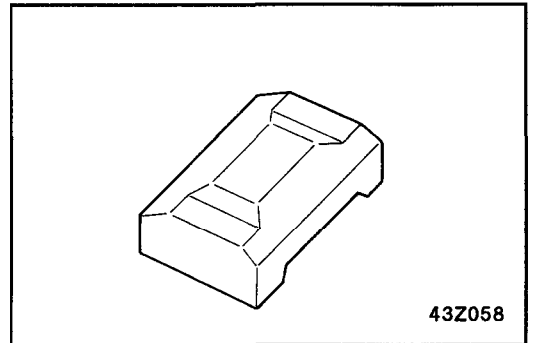

GEARS

1. Check the bevel gear and clutch gear teeth for damage and wear.
2. Check the gear cone for rough surfaces, damage or wear.
3. Check the gear bore for damage or wear.

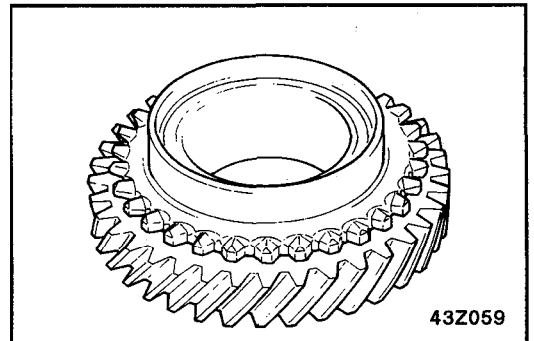

ASSEMBLY

1. Install the synchronizer hub and sleeve so that they are positioned as shown in the figure.
2. Engage the synchronizer sleeve and hub.
3. Install the synchronizer spring with keys.
For installing, refer to the fifth speed synchronizer assembly section.

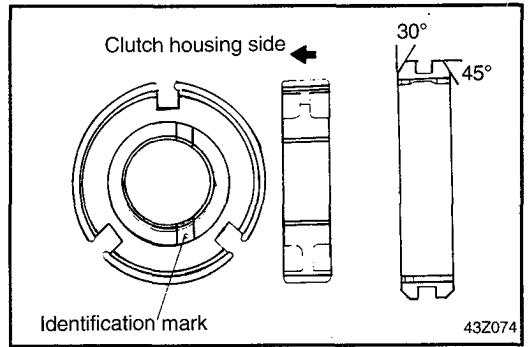

4. Install the needle roller bearing and third speed gear on the input shaft.
5. Install the third-fourth gear synchronizer assembly on the input shaft using the special tool (09432-33300).

CAUTION

1. **When installing the synchronizer assembly, make sure that the three synchronizer keys are seated correctly in their respective grooves of the synchronizer ring.**
2. **After installing the synchronizer assembly, check that third gear rotates smoothly.**

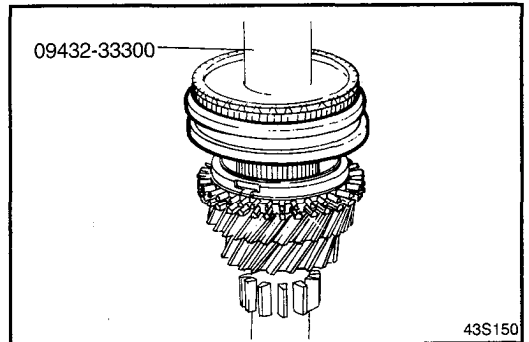

6. Install the fourth speed gear sleeve using the special tool (09432-33300).
7. Install the needle roller bearing and fourth speed gear assembly.

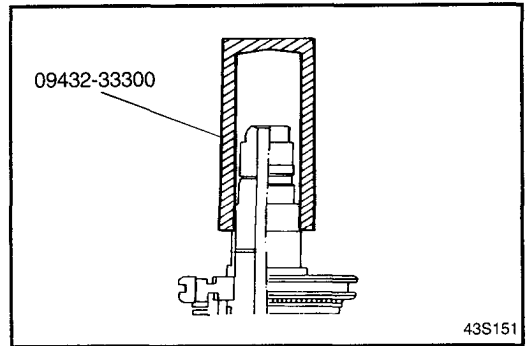

8. Install the taper roller bearing and fifth speed gear sleeve using the special tool (09432-33300).
9. Install the front bearing.

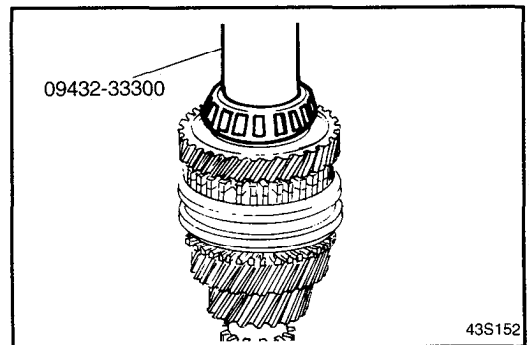

OUTPUT SHAFT

COMPONENTS

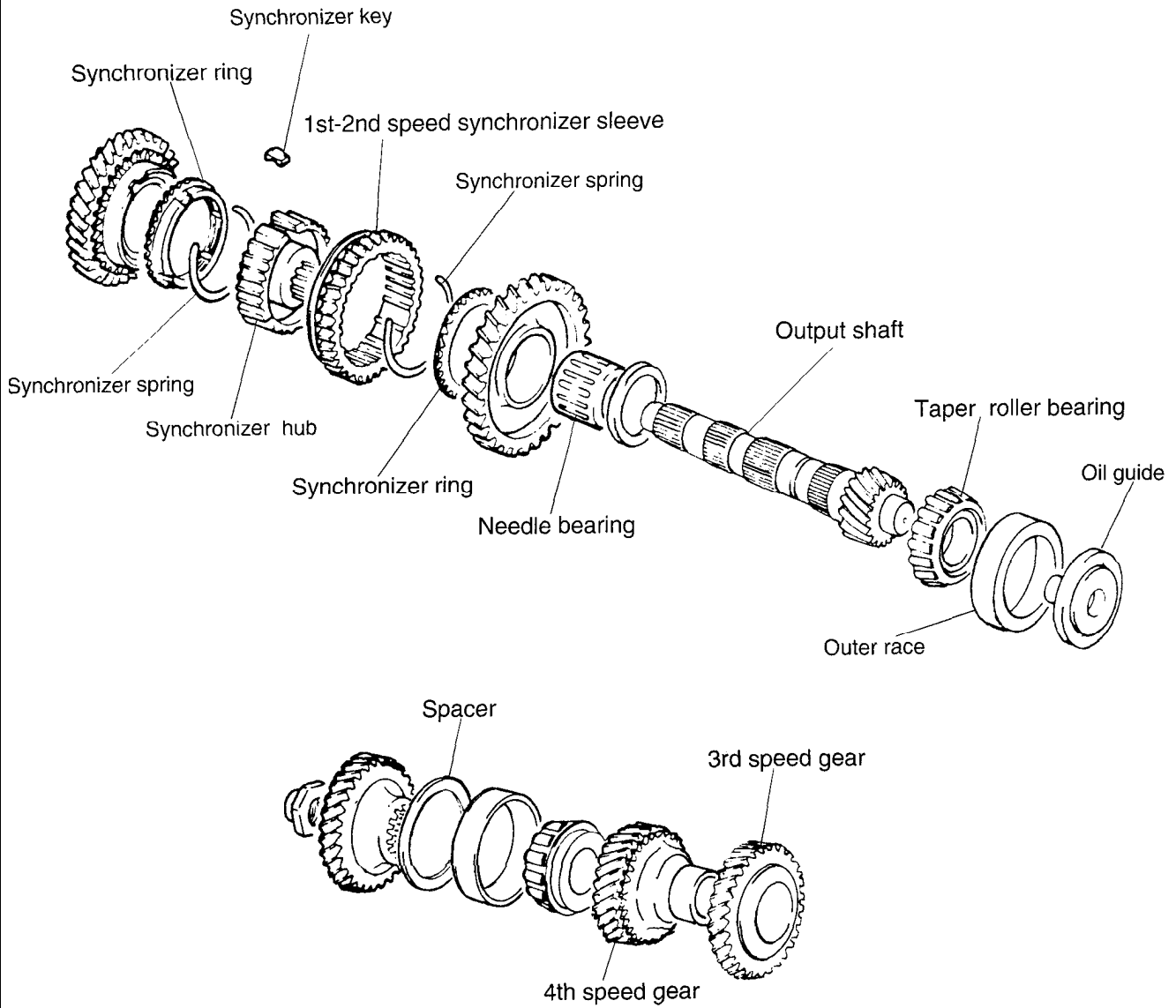

DIASSEMBLY

1. Remove the taper roller bearing, fourth output gear, spacer, third output gear, second speed gear assembly with second gear sleeve and needle roller bearing, first speed gear assembly with needle roller bearing and spacer and steel ball. Using the special tool (09432-33200).
2. Remove the rear taper roller bearing using the special tool (09433-21400).

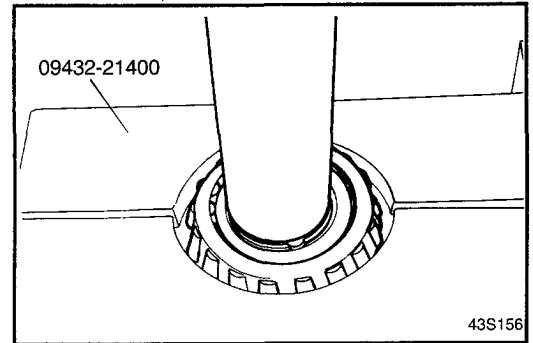
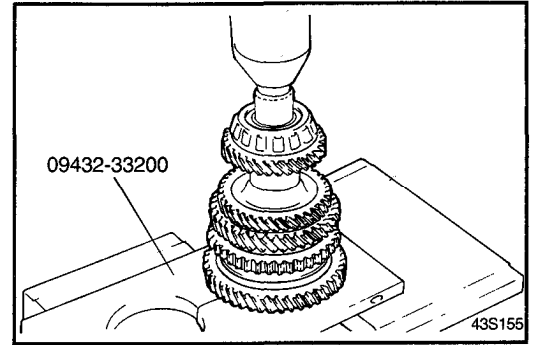

INSPECTION

OUTPUT SHAFT

1. Check the outer surface of the output shaft where the needle bearing is mounted for damage or abnormal wear [portion (A)].
2. Check the splines for damage or wear.

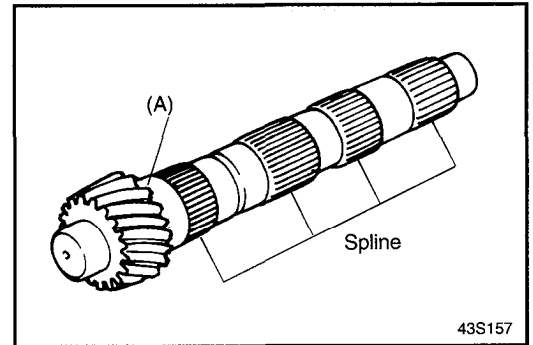

NEEDLE BEARING

1. Install the needle bearing on the shaft with the bearing sleeve and gear. Check that it rotates smoothly without abnormal noise or play.
2. Check the needle bearing cage for distortion.

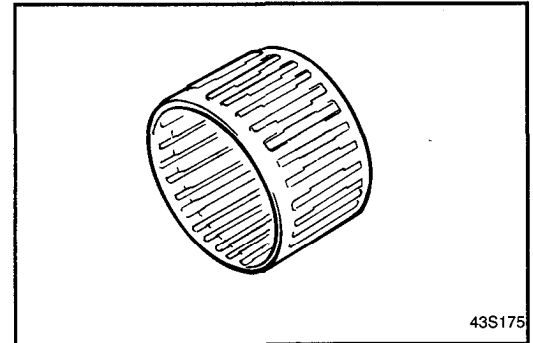

SYNCHRONIZER RING

1. Check the clutch gear teeth for damage.
2. Check the internal surface for damage, wear or broken grooves.

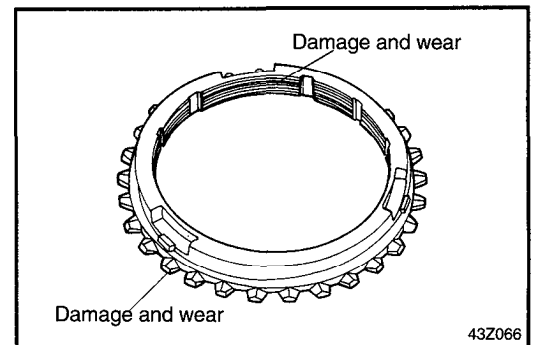

3. Push the synchronizer ring toward the clutch gear and check clearance "A". Replace if it is not within specifications.

Limit : 0.5 mm (0.02 in.)

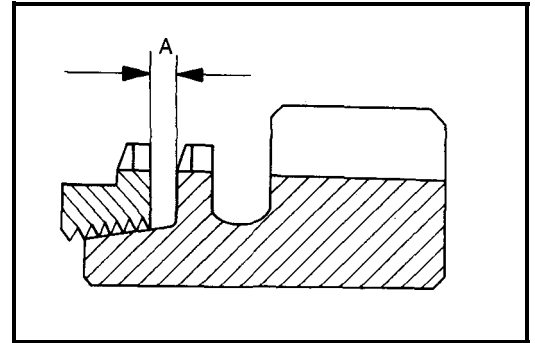

SYNCHRONIZER SLEEVE AND HUB

1. Install the synchronizer sleeve on the hub and check that it slides smoothly
2. Check that the sleeve is free from damage.
3. Check for wear of the hub end surfaces (in contact with each gear).

Caution:

Replace the synchronizer hub and sleeve as a set.

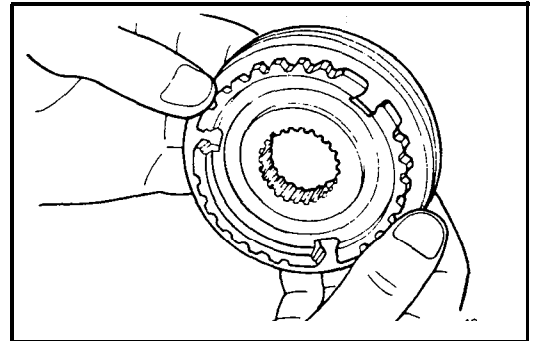

SYNCHRONIZER KEY AND SPRING

1. Check for wear of the synchronizer key center protrusion.
2. Check the spring for weakness, distortion or damage.

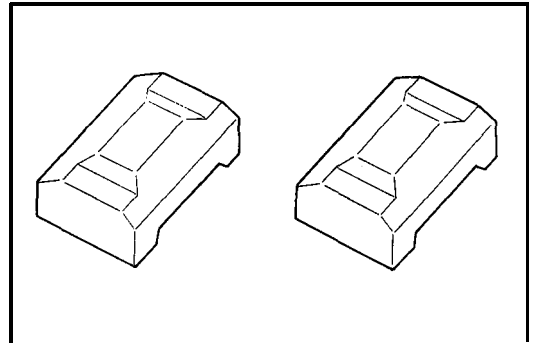

GEARS

1. Check the bevel gear and clutch gear teeth for damage or wear.
2. Check the gear cone for rough surfaces, damage or wear.
3. Check the gear bore for damage or wear.

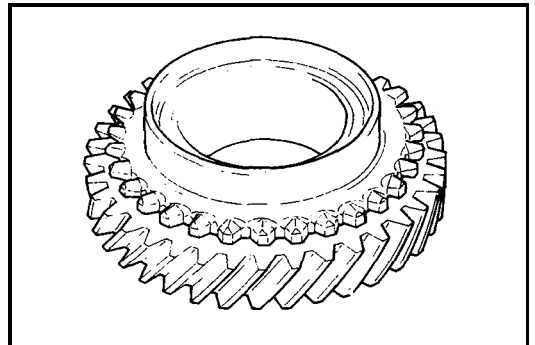

ASSEMBLY

1. Install the steel ball and spacer to the output shaft.
2. Install the first speed gear assembly with needle bearing.

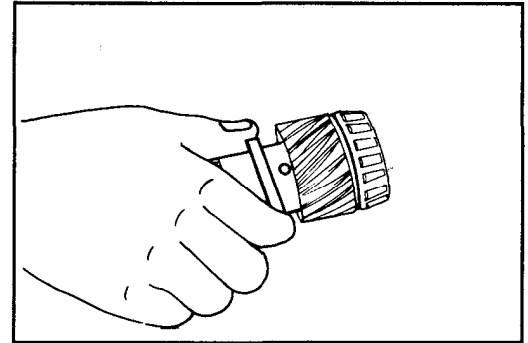

3. Combine the first-second gear synchronizer hub and sleeve.

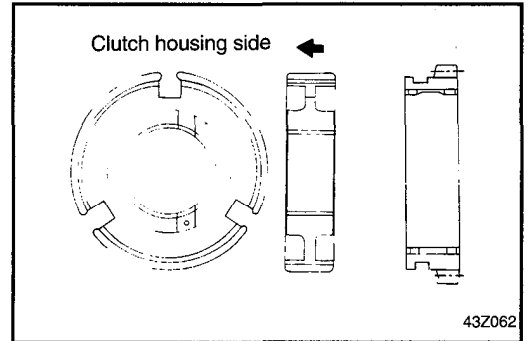

4. The synchronizer sleeve has teeth missing at six places. Assemble the hub to the sleeve so that the center tooth between the two missing teeth will touch the synchronizer key.

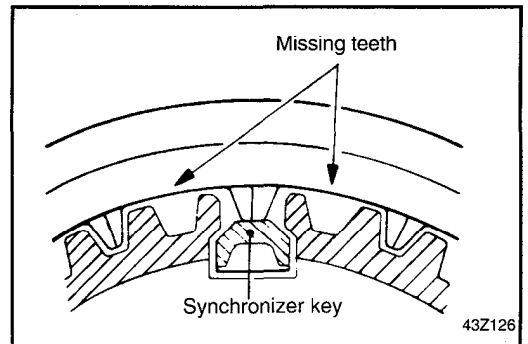

5. Install the synchronizer spring so that its protrusion may be engaged in the groove of the synchronizer keys.

CAUTION

When installing the synchronizer springs, make sure they are not facing the same direction.

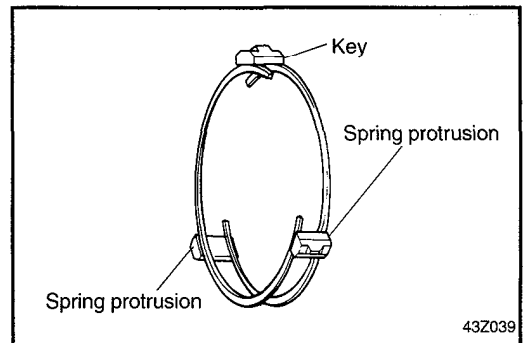

6. Install the first-second speed gear synchronizer assembly over the output shaft using the special tool (09432-22000).

CAUTION

- 1) **When installing the synchronizer assembly, make sure that the three synchronizer keys are seated correctly in their respective groove on the synchronizer ring.**
- 2) **After installation of the synchronizer assembly, check that first gear rotates smoothly.**

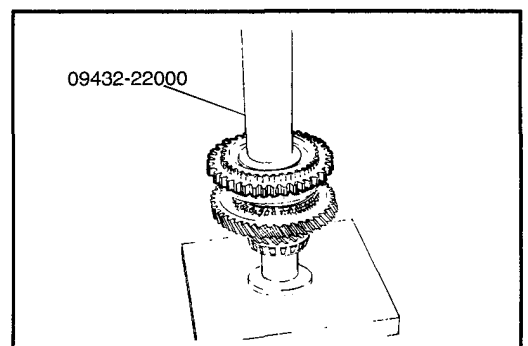

7. Install the second speed gear with needle roller bearing and bearing sleeve using the special tool (09432-22000).

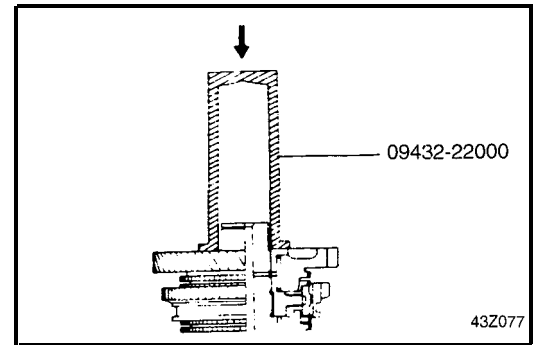

8. Install the third speed gear and spacer.
9. Install the fourth speed gear.

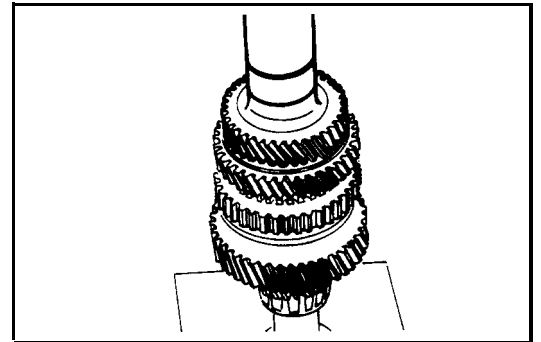

10. Install the taper roller bearing using the special tool (09432-22000).

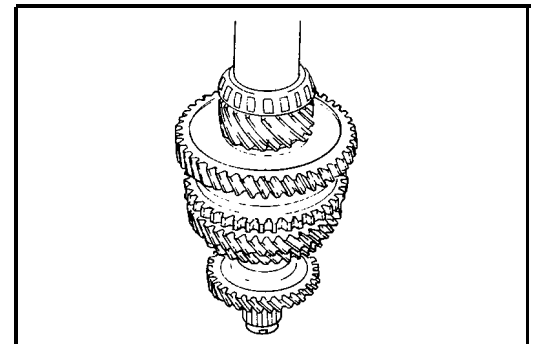

11. Install the rear side taper roller bearing using the special tool (09432-22000).

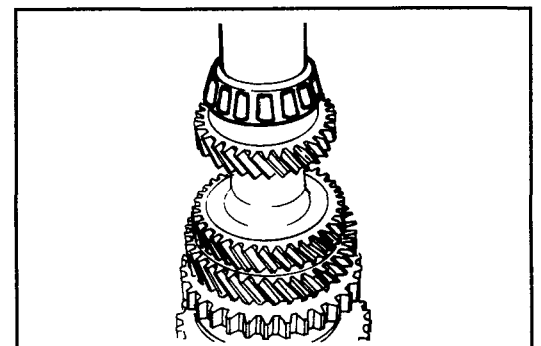

SHIFT FORK AND CONTROL SHAFT ASSEMBLY

COMPONENTS

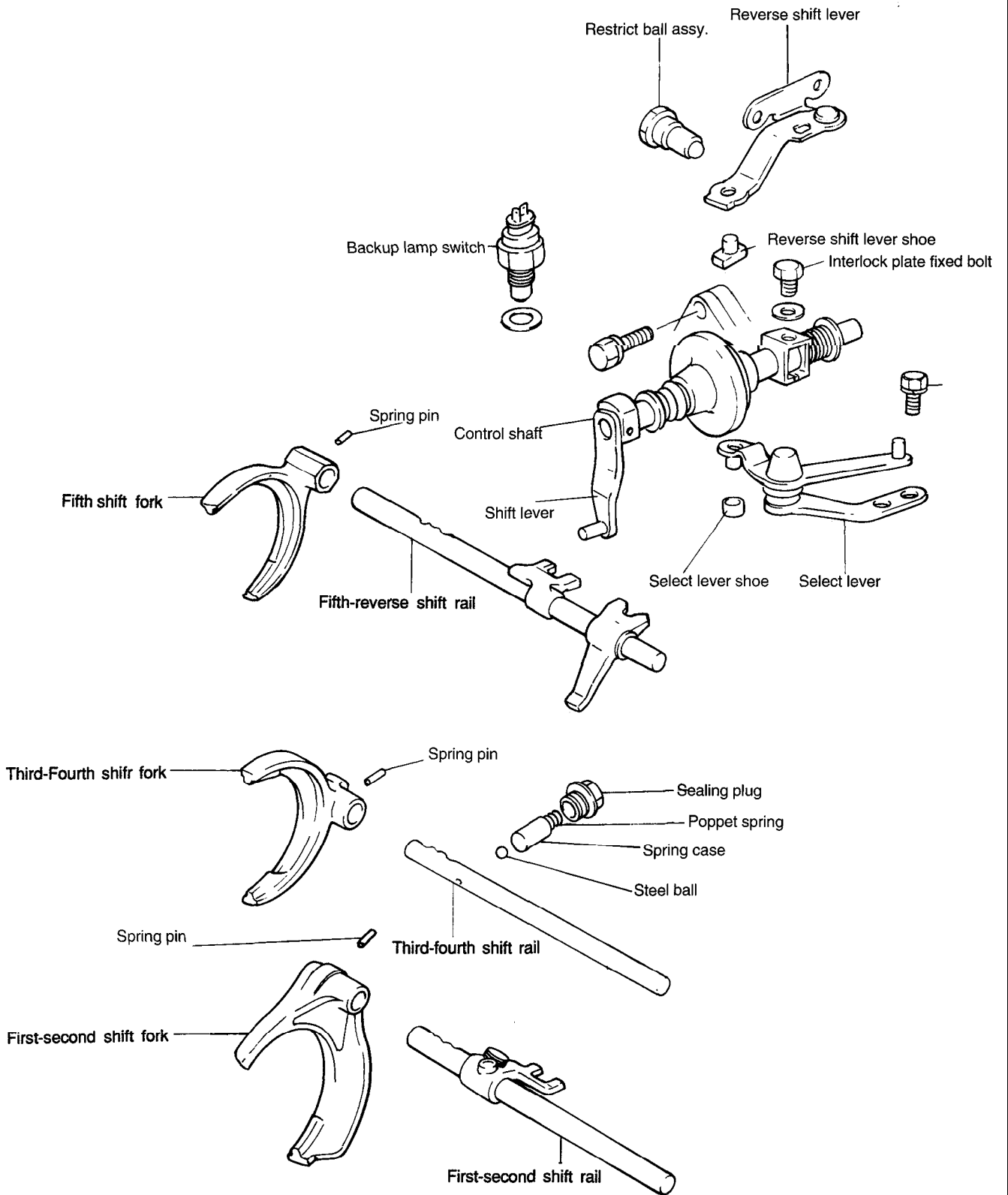

DIFFERENTIAL

COMPONENTS

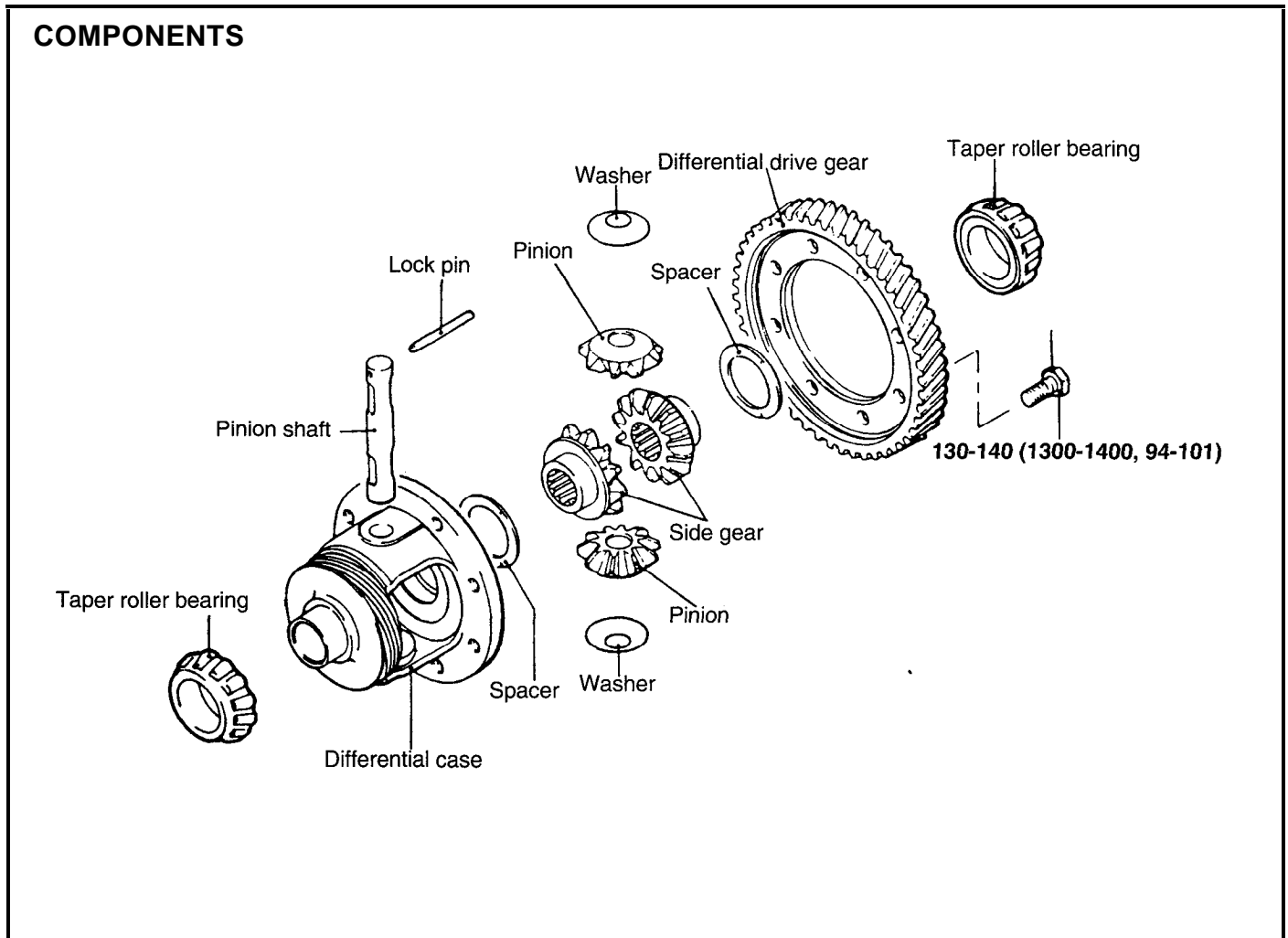

DISASSEMBLY

1. Clamp the differential case in a vise.
2. Remove the differential drive gear retaining bolts and remove the differential drive gear from the case.

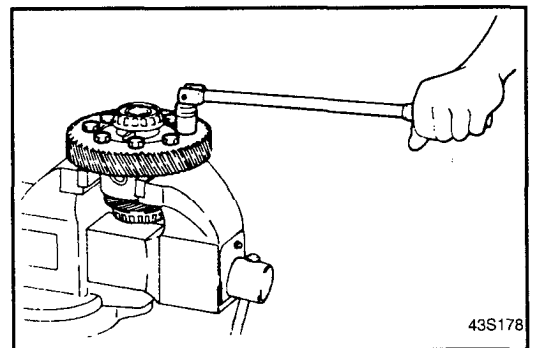

3. Remove the ball bearings using the special (09433-21000).

CAUTION

Do not reuse the bearing removed from the shaft.

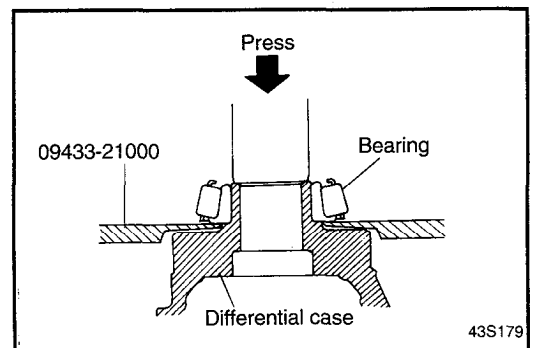

4. Drive out the lock pin from the hole A using a punch.
5. Drive out the pinion shaft.
6. Remove the pinion gear, washers, side gears and spacers.

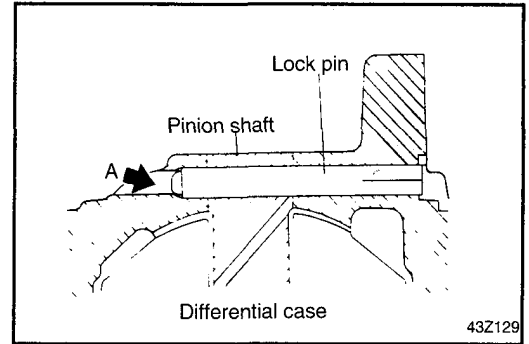

ASSEMBLY

1. Install the spacer on the back of the side gear and then install the gear in the differential case.

CAUTION

1. When installing a new side gear, use a spacer of medium thickness [0.93-1.00 mm (0.036-0.04 in)].
2. Do not reuse the lock pin.
3. The lock pin head must be sunk below the flange surface of the differential case.

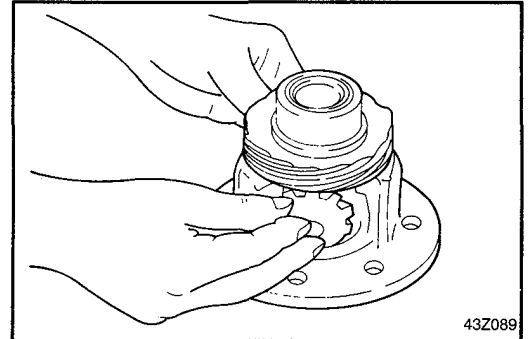

2. Set the washer on the back of each pinion and insert the two pinions to specified position while engaging them with the side gears by turning them.
3. Inset the pinion shaft.

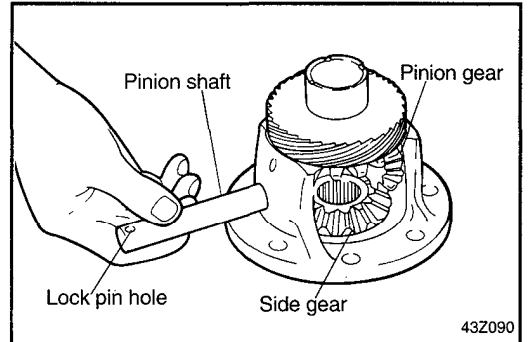

4. Measure the backlash between the side gears and pinions.

**Standard value : 0.025-0.150 mm
(0.001-0.006 in.)**

5. If the backlash is out of specification, disassemble and install the correct spacer, reassemble and remeasure.

Caution:

Adjust the backlash or both side gears to the same specification.

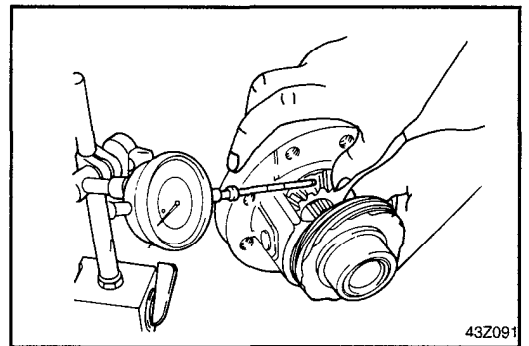

6. Align the pinion shaft lock pin hole with the case lock pin hole and insert the lock pin.

Caution

1. Do not reuse the lock pin.
2. The lock pin head must not protrude more than 3 mm (0.118 in.).

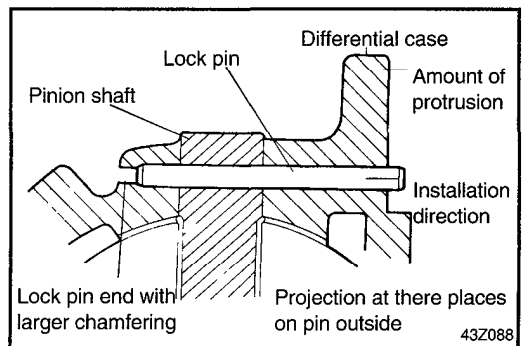

7. Install the ball bearings on both sides of the differential case using the special tool (09455-21100).

Caution

When press-fitting the bearings, press on the inner race only.

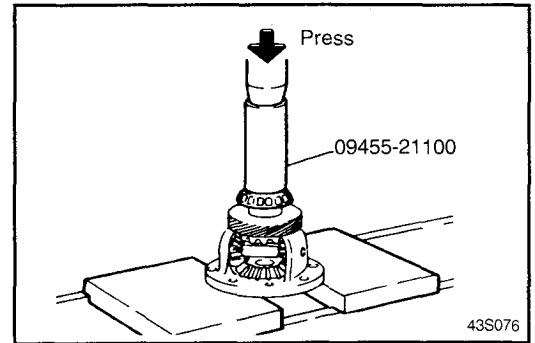

8. Tighten to specifications using the sequence shown in the illustration.

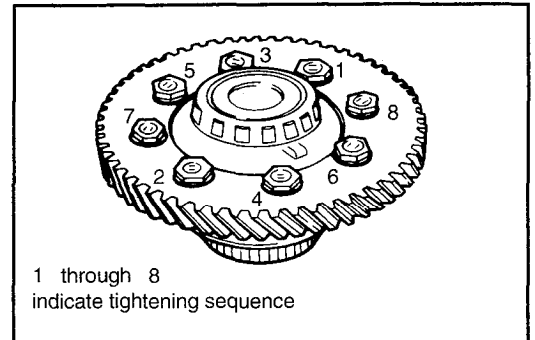

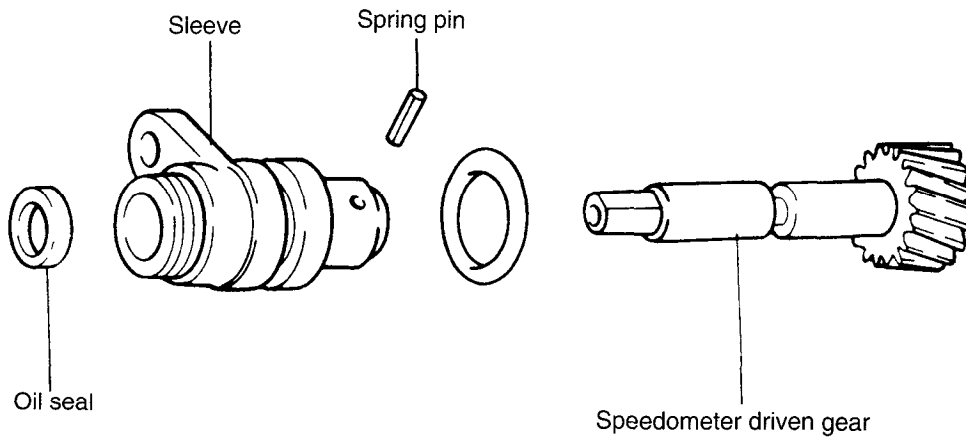
SPEEDOMETER DRIVEN GEAR ASSEMBLY**COMPONENTS****ASSEMBLY**

1. Apply gear oil sparingly to the speedometer driven gear shaft and insert the shaft.
2. Install the spring pin in such a way that the slit does not face the gear shaft.

